

Worldwide Pollution Control Association

WPCA/FirstEnergy Biomass Seminar

Akron, Ohio
December 3, 2009

All presentations posted on this website are copyrighted by the Worldwide Pollution Control Association (WPCA). Any unauthorized downloading, attempts to modify or to incorporate into other presentations, link to other websites, or obtain copies for any other uses than the training of attendees to WPCA Conferences is expressly prohibited, unless approved in writing by the WPCA or the original presenter. The WPCA does not assume any liability for the accuracy or contents of any materials contained in this library which were presented and/or created by persons who were not employees of the WPCA.



Visit our website at www.wpca.info

W
P
C
A

Schenck Process weighing feeding screening automation conveying



WPCA / First Energy Biomass Seminar

1 2 5 10 20 40 75 125 years

© Schenck Process 2009
Management Meeting 2009



**Handling Biomass and
Solid Alternative Fuels**
Simon Shipp
December 3rd 2009



we make processes work

Contents

1 Introduction, Market Predictions, General Considerations,

2 Plant Arrangements

3 Unloading Systems

4 Conveying Systems

5 Storage Systems

6 Combustion Feeding Systems

7 Conclusions and Developments



1

Introduction, Market Predictions, General Considerations



Some Market Predictions

US investment in biomass power generation was at \$0.4 billion in 2008, grew by \$0.1bn 2007 - 2008. Currently remains the lowest clean energy investment level compared to wind at \$17.7 billion.

Biomass powers attraction predicted to rise as the deficiencies and practical limits of solar and wind are revealed and policy change favors lower carbon thermal generation options.

- Investor interest is reemerging, climate change legislation could incentivize investors further
- Fuel supply challenges present some practical hurdles
- Fossil fuel stability and volatility cycle may assist
- New conversion technologies make process efficiency gains that increase investment viability
- Biomass better suited to small scale, does not always scale up well for large wholesale power market
- Economics work well in CHP projects

got biomass?

General Considerations - Fuel Types

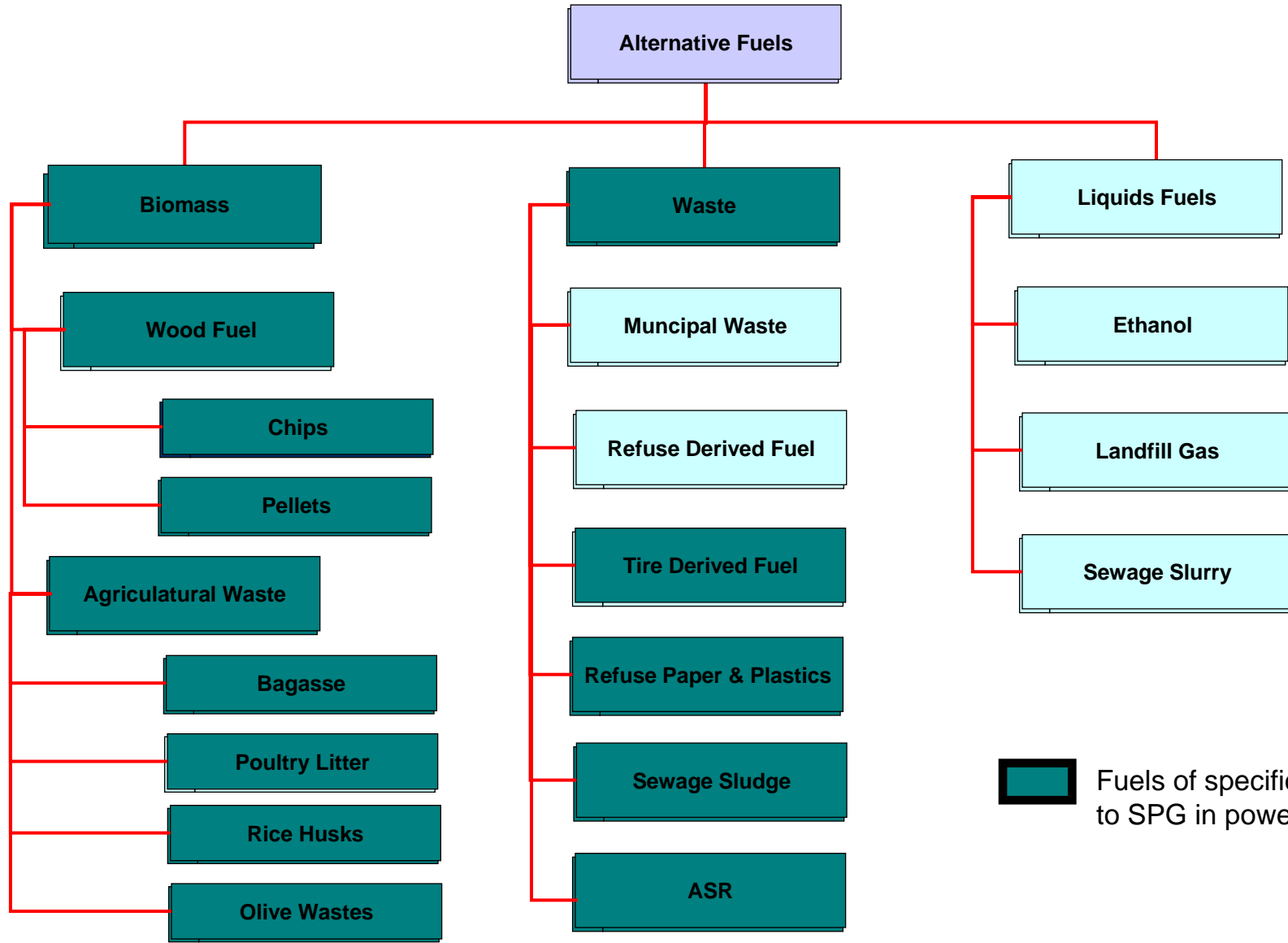

Fuel - Summary

Tons of Fuel to Replace 1 ton Coal

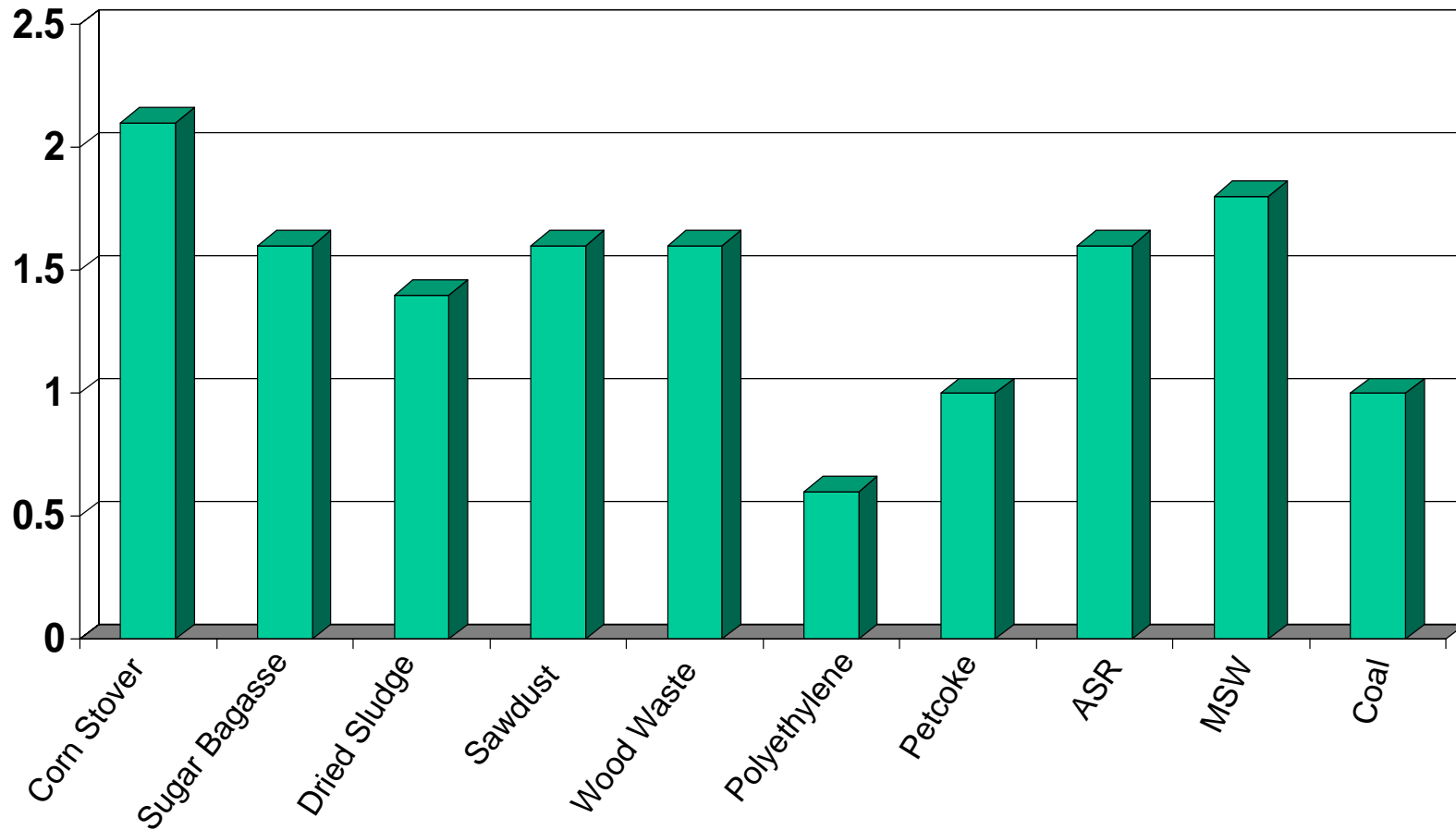

Murray and Price, June 2008, LBNL-525E

General Handling System Considerations (The Three Most Important Things)

“Material, Material, Material”

Material Challenges

- Fuel character variability and changes in supply sources demand flexible handling systems
- Supplementary fuel additions and blending present additional control requirements
- Adapting existing systems and adding new fuels create significant system routing issue
- High volumes of tramp and oversize in waste materials are creating new design constraints

“One Mans Garbage has Become Another Mans Fuel”



General Considerations, Continued



Key Considerations Include:

- Material, Material, Material
- Fuel supply dedicated or multi-fuel flexible including blending fuel types
- In coming transportation, truck management and/or specific unloading requirements
- Storage considerations, indoor, outdoor, does the fuel change due to climate
- Transfer, will material or plant location create design constraints or prevent the use of certain options
- Processing does material require cleaning, screening or size reduction
- Holding, does material character prevent the use or alter the design of bins and hoppers
- Fuel feeding does the system require tight feed control, is fuel blended before combustion
- Can emissions be reduced or boiler performance optimized with a gravimetric feed control
- By product handling, the ash can be difficult to handle from biomass plants

Feeding and Handling System

Do not underestimate the material handling and feeding aspects of biomass and alternative fuels

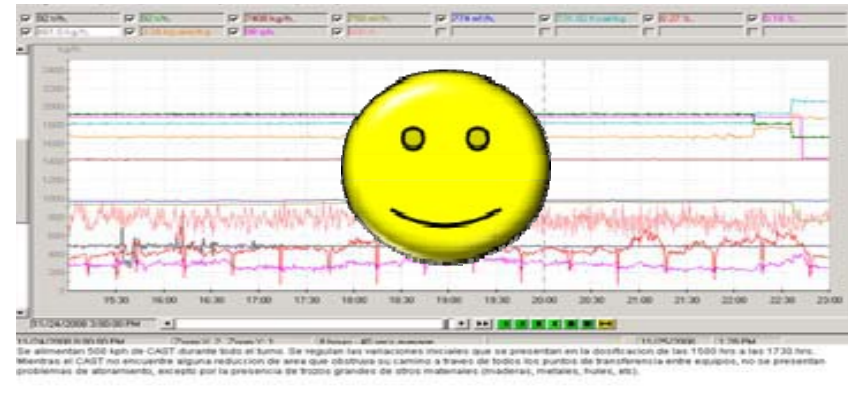

4

Plant Arrangements



Plant Arrangements



We typically look at three general handling arrangement types:

Arrangement One, Dedicated Biomass System Conversion or New Build

Complete system from intake to Boiler. 200mw or less normally. Typical plant size of 50mw. Road truck unloading , occasionally rail transport. Covered storage with automated reclaim. Boiler feeding is volumetric or potentially gravimetric

Arrangement Two, Supplementary Fuel Addition

Addition of a defined % of new fuel onto the existing intake and handling system. Fuel is normally added before the local boiler storage bunker. The addition is most likely as a volumetric feed.

Arrangement Three, New Fuel Addition

The installation of a complete and separate system to handle the wholly new fuel. Can be prior to existing combustion process or as a stand alone feeding system. Gravimetric or volumetric control.

One - Biomass System

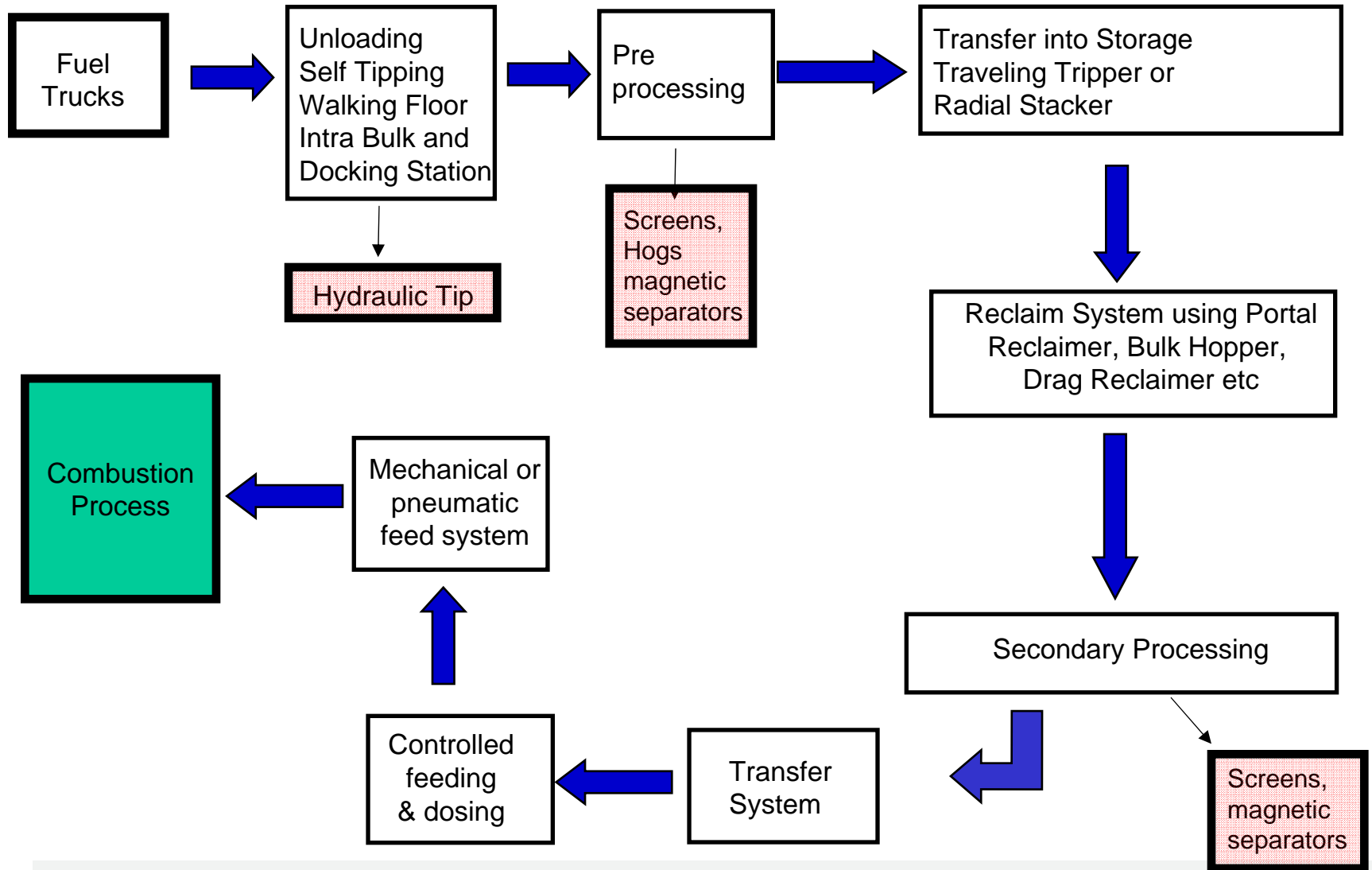

Three – Stand Alone Biomass Fuel Addition

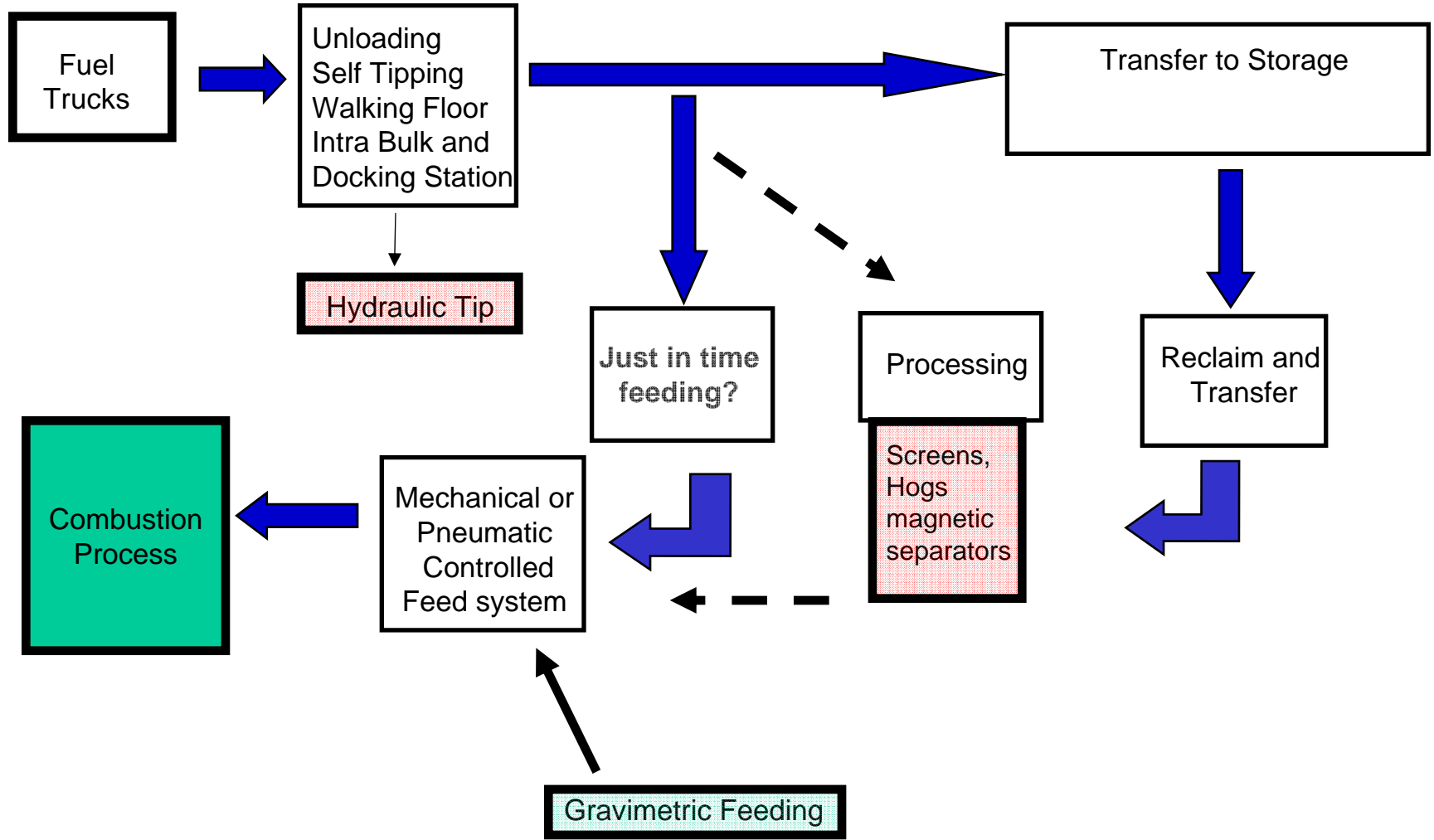

3

Unloading Systems

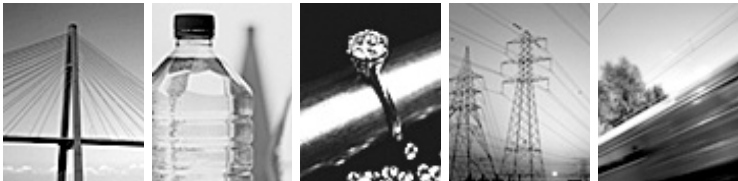

Unloading Systems Options

Unloading System	Materials Handled	Rates	Comments
Open Storage (open or covered Fuel Hall)	Wood chip, poultry litter	Dependent on truck logistics	Simple unloading to fuel halls
Drive Over or Drive Up Truck	Woodchip, TDF, MBM, Poultry Litter	10 - 15 trucks per hour	Can use multiple truck designs
Self tipping rear discharge (above ground)	Woodchip, MBM, Poultry Litter, Sludge	6 – 8 trucks per hour	Can also act as volumetric feed and storage device
Open Top Live Bottom Bin	Woodchip, ASR, Bagasse etc	Normally low loader fed	Receives from loader
Walking Floor Trailer	Woodchips, ASR, Bagasse	Up to 75tph normally	Typically used for combined store/unload
Container Dumping	ASR,	4 – 5 containers per hour	Totally sealed versions available
Rail Car Unloading	Woodchip	Between 10 – 4000tph material dependent	Designs vary by application

Open Storage



Open fuel hall examples shown include fuel hall for 7000cu/ft pr hour system conveying woodchips.

Fuel hall has fire suppression system and water misting system.

Drive Over Drive Up Truck Unloading

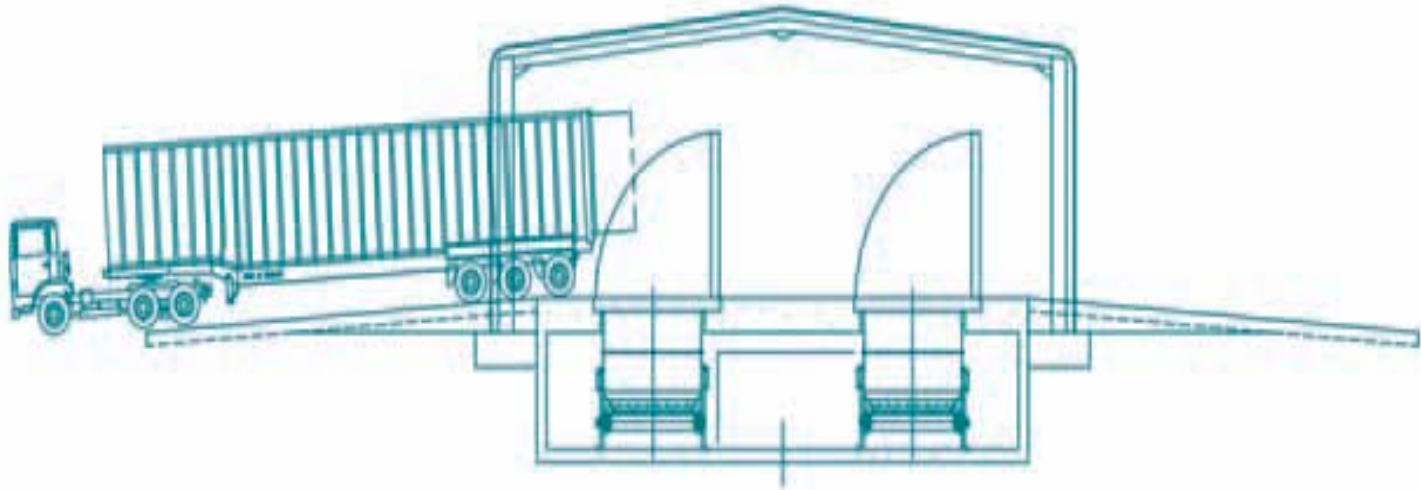

Fully enclosed drive over system enabling center, walking floor and self tipping truck discharge of raw fuel.

This type of above ground system eliminates hoppers and chutes allowing multiple fuels to be unloaded with the same system and preventing system choke points

Rates vary with fuel type, truck design and even operator skill, normal rates can exceed 12 trucks per hour.

Self Tipping Trailers



Fully enclosed and automated unloading for multiple materials. Above ground design eliminates hoppers, chutes and bins below grade. This reduces cost and removes potential choke points. This system type can handle multiple materials and provide volumetric feed control to downstream conveyors and processes.

Animation

Open Top Live Bottom Bin



Live bottom hoppers can be used for system feeding and for receiving bulk fuels from storage using low loaders. The live bottom use multiple screws to feed the conveying system. Materials handled have included wood, wood wastes, automotive shredded residue and pelletized fiber fuels.

Walking Floor Trailers (Docking Station)

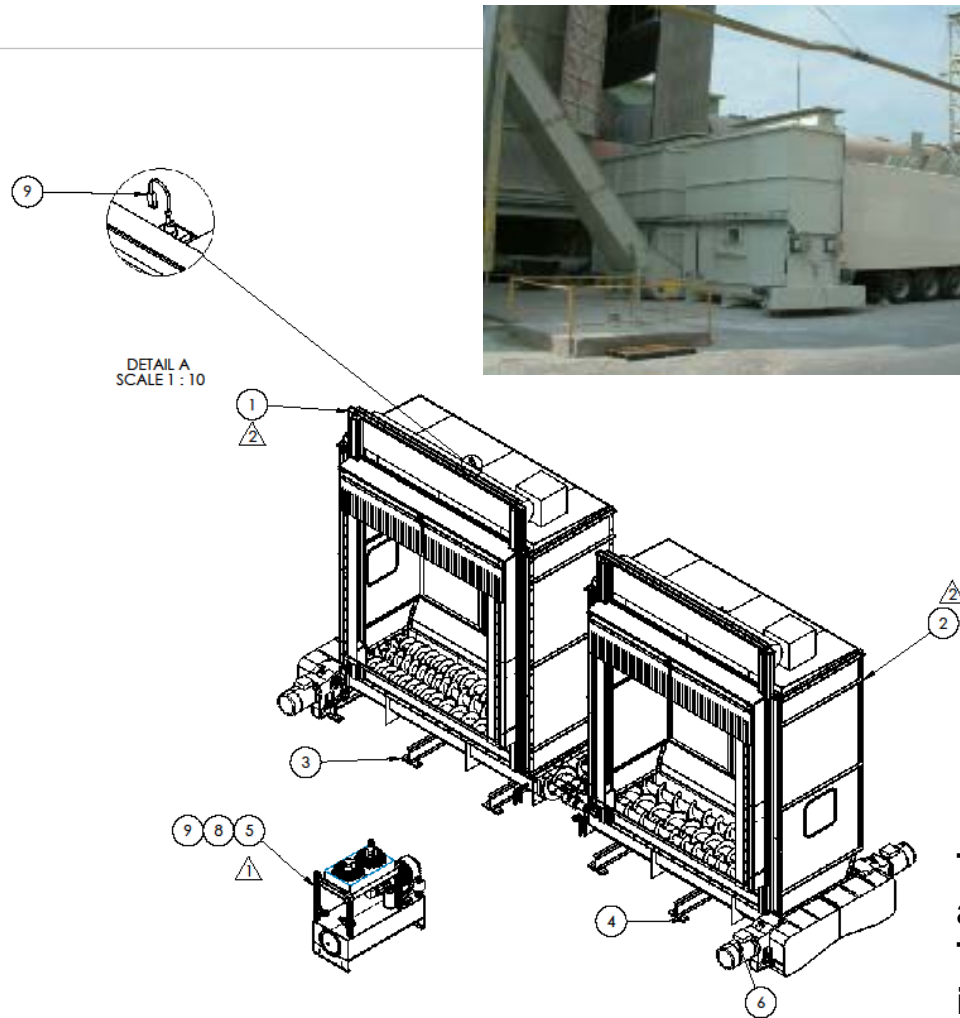

The station uses a neoprene buffer to create a soft seal around the trailer doors. This enables material from the trailer to fall into the live bottom hopper for accurate flow control to the storage or process system.

Container Dumping



Container Tipping System



Container placed within fully enclosed vented enclosure

Drive Over and Rail Unloading

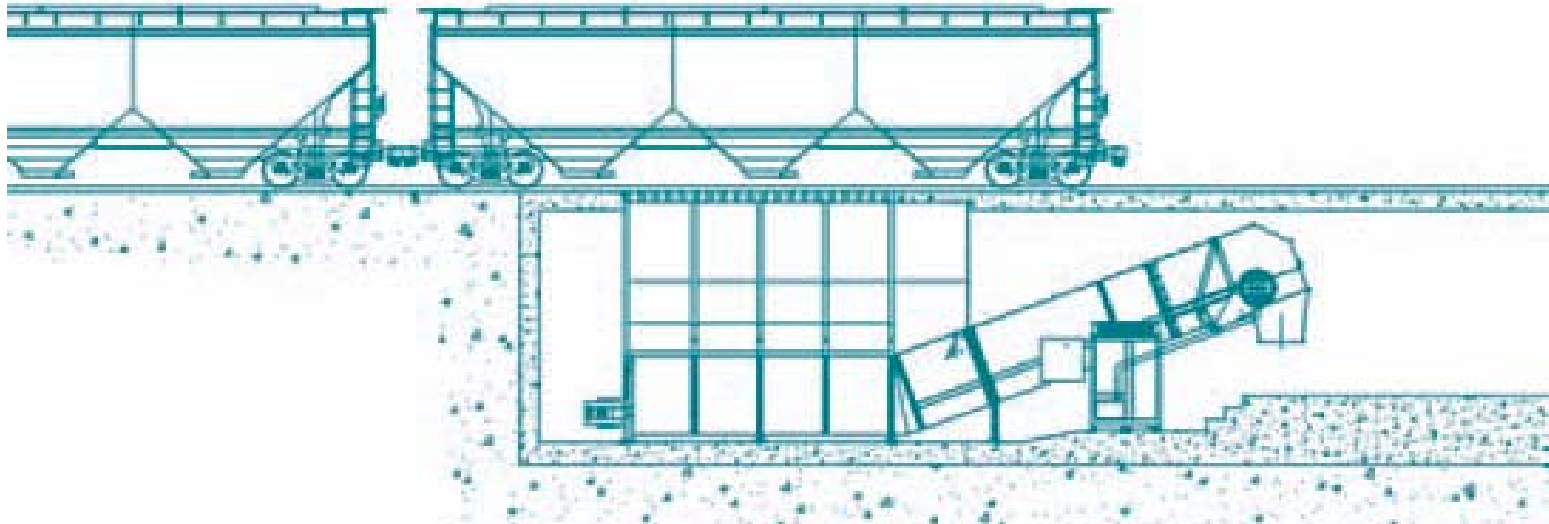

Rail unloading for biomass can be very difficult. Materials nest and interlock in hoppers and bins this forces extensive equipment costs and civil installation costs to design systems below grade.

Combining the receiving and conveying device into a single unit eliminates conventional hoppers and material holding systems and allows feeding to the downstream conveyor to take place with greater ease.

4

Conveying

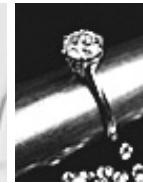

Conveying Options



Conveyor Type	Materials Handled	Distance and Rates	Comments
Belt Conveyor	Wood chip, poultry litter, TDF	Up to 1000tph typical biomass system	Long distance
Tube Conveyor	Woodchip, TDF, MBM, Poultry Litter	500tph typical for biomass	Fully enclosed, flexible routing and long distance
U Tube Conveyor	Woodchip, MBM, Poultry Litter, Sludge	500tph typical for biomass	Can be fully enclosed
Pocket Belt	Woodchips, ASR, Bagasse	Most applications under 200tph biomass	Used for higher angle lifts and vertical to horizontal transitions
Chain Conveyor	Woodchip, poultry litter, ASR,	Most applications under 200tph for biomass	Fully enclosed with multiple outlets
Pneumatic Conveying	Woodchip, ASR	Under 100tph for biomass typically	Flexible routing

Conveying (Belt Conveyor)



Conventional covered conveyor belts are still an effective and perhaps the simplest means to transfer biomass and solid alternative fuels. They lack some routing flexibility, however they are very practical and can handle multiple material characters and types.

Conveying (Tube Conveyor)



Modern Tube conveyors fully enclose the material inside the folded belt. The modern system are utilizing simpler idler systems and offer total enclosure and flexible routing options at much lower capitol costs than previously available.

Conveying (U Conveyor)



The U conveyor creates a trough reducing dusting and spillage and providing far greater material control than a conventional belt.

The systems are typically used in conjunction with full system enclosure when environmental barriers are a must.



Conveying (Pocket Belt)



Pocket belts allow difficult materials to be handled at steeper inclines and even vertically. Routing can also be in more than one plane offering flexible inlet and outlet location.

The systems offer improved spillage control and can be totally enclosed easily . Systems can be used to meet both inside and outside installation demands.

Conveying (Chain Conveyor)



The conventional drag or en-masse chain conveyor is still a highly viable option even for longer distance applications.

The systems fully enclosed design eliminates dusting and barriers the material from the weather and effects of environmental Conditions.

Multiple inlet and outlet combinations make the chain conveyor an excellent choice to collect and/or feed from multiple material points.



Conveying (Pneumatic Conveyor)



The use of dilute phase conveying will grow due to the success seen handling solid alternative fuels and biomass in cement kiln Applications.

The systems are able to better handle the biomass material characters and offer a fully enclosed and flexible routing option for certain material characters. The latest generation of feeders are radically lower in maintenance requirement.

Normal operating range is up to 7000 cu/ft per hour with a 45 lbs/cuft material with a 1.5 inch maximum particle size.

Conveying (Screw Conveyor)



Sometime the screw conveyor can be the best way, despite some restrictions on certain fuels the screw has benefits providing a combined pre-feed and conveyor for shorter distance lower rate applications.

5

Storage



Storage Options

Storage Type	Materials Handled	Application	Comments
Storage Hall	Wood chip, poultry litter, TDF	Large covered capacity used for fuels adversely effected by moisture	Use of bridge conveyors is possible
Silos	Woodchip, TDF, MBM, Poultry Litter	Enclosed storage	Fully enclosed
Live Bottom Bins	Woodchip, MBM, Poultry Litter, Sludge	Combined feed and storage device	Smaller local storage
Walking Floors	Woodchips, ASR, Bagasse	Can be used to store and feed material	Integrated trailer hydraulic system
Integrated receiving and Storage Systems	Woodchip, poultry litter, ASR,	Truck unloading and process feed	Volumetric control to downstream process
Open Stockpiles	Woodchip, ASR	Outdoor fuel pile	Normally created by stacker

Enclosed Storage – (Storage Hall)



Fully covered storage halls provide complete weather protection, but require extensive real estate and civil costs. Filling the hall can be manual or fully automated using overhead bridge and pile reclaiming.

For some fuel types the reclaim is completed using grab cranes to reduce operator material contact for health and safety reasons.

Storage – (Silos)



Completely enclosing the material in silos provides the best barrier. The biomass materials can present unique filling and especially discharging problems. The system on the left overcomes this with a 100% recirculation system to keep the material mobile at all times.

Storage – (Live Bottom Bins)

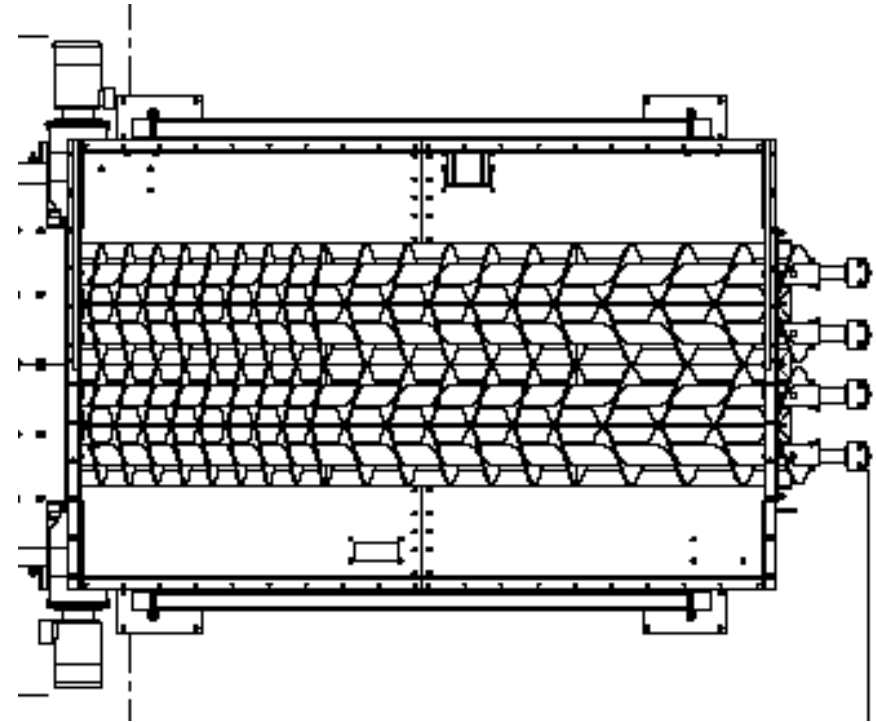

Live bottom storage provide the best opportunity to discharge reliably from intermediate bins and hoppers within the system.

Typical system use multiple screws in the bin base or sweep agitators to reduce bridging and hang ups at discharge.

Storage – (Walking Floors)



Hydraulic walking floors or ladder floors allow large volumes of material prone to discharge issue to be positively displaced onto the downstream conveying system. Although generally reliable they can be less resilient to tramp material contained hidden within the stockpile.

Storage – (Receiving and Storage Systems)



Receives material form self tipping trucks and stores load for volumetric feed to downstream conveying and process system. Reduces cost and enables multiple fuels to be handled in the same system.

Storage – (Open Stockpiles)



Open stockpile is the simplest form of storage and is effective for high volumes when weather and environmental impacts can be successfully managed.

6

Combustion System Feeding



Boiler Feeding Systems

	Feeding System	Materials Handled	Application	Comments
Gravimetric +/- 0.5% Material dependent	Mechanical (Belt feeder)	Wood chip, poultry litter	Specifically for biomass	
	Mechanical (Screw)	Woodchip, TDF, MBM, Poultry Litter	Specific biomass design	Fed by agitated hopper
	Pneumatic (Fed by screw or belt)	Woodchip, MBM, Poultry Litter, Sludge	Dilute phase conveying to burner	Technology used for kiln firing
	Screw	Woodchip, ASR, Bagasse etc	Standard feeding approach	Standard feed approach
Volumetric +/- 5% Material Dependent	Chain Conveyor	Woodchips, ASR, Bagasse	Used to deliver fuel	Typically ahead of screw feeder
	Belt	ASR,	Simple volumetric feeder	Simple belt feeder

Gravimetric – (Mechanical Belt)



- Need to be designed specifically for biomass fuels
- High measuring load / tare load ratio
- Special weigh belt (very light) for reduced tare weight
- Special weigh bridge design for increased measuring load

Gravimetric – (Mechanical Screw)

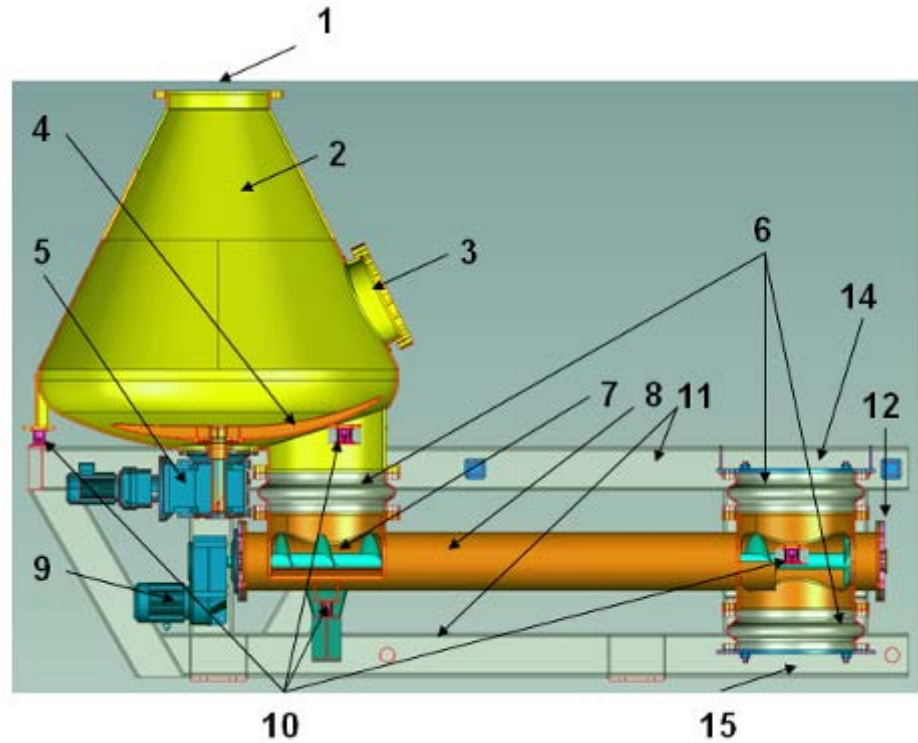

Fig. 2: Principal Features

The system weighs the bin and screw at two points to determine a gravimetric feed rate at of +/- 0.5%*

The system successfully handles the variation of bulk density seen in biomass fuels.

* Accuracy depends on bulk density and material character

- 1 Material inlet
- 2 Bin for material
- 3 Inspection opening
- 4 Rotor of activator
- 5 Drive of activator
- 6 Flexible joints
- 7 Feeding screws
- 8 Screw feeder housing
- 9 Screw feeder drives
- 10 Load cells
- 11 Frame
- 12 Bearings of feeding screws
- 14 Placement of filter or pressure compensator
- 15 Material outlet

MultiFlex
Video

Gravimetric – (Pneumatic fed by belt or Screw)



The screw weigh feeder operates with gravimetric accuracy to supply the pneumatic feeding system to the burner or combustion chamber with steady state fuel feeding rate.

Volumetric – (Screw)

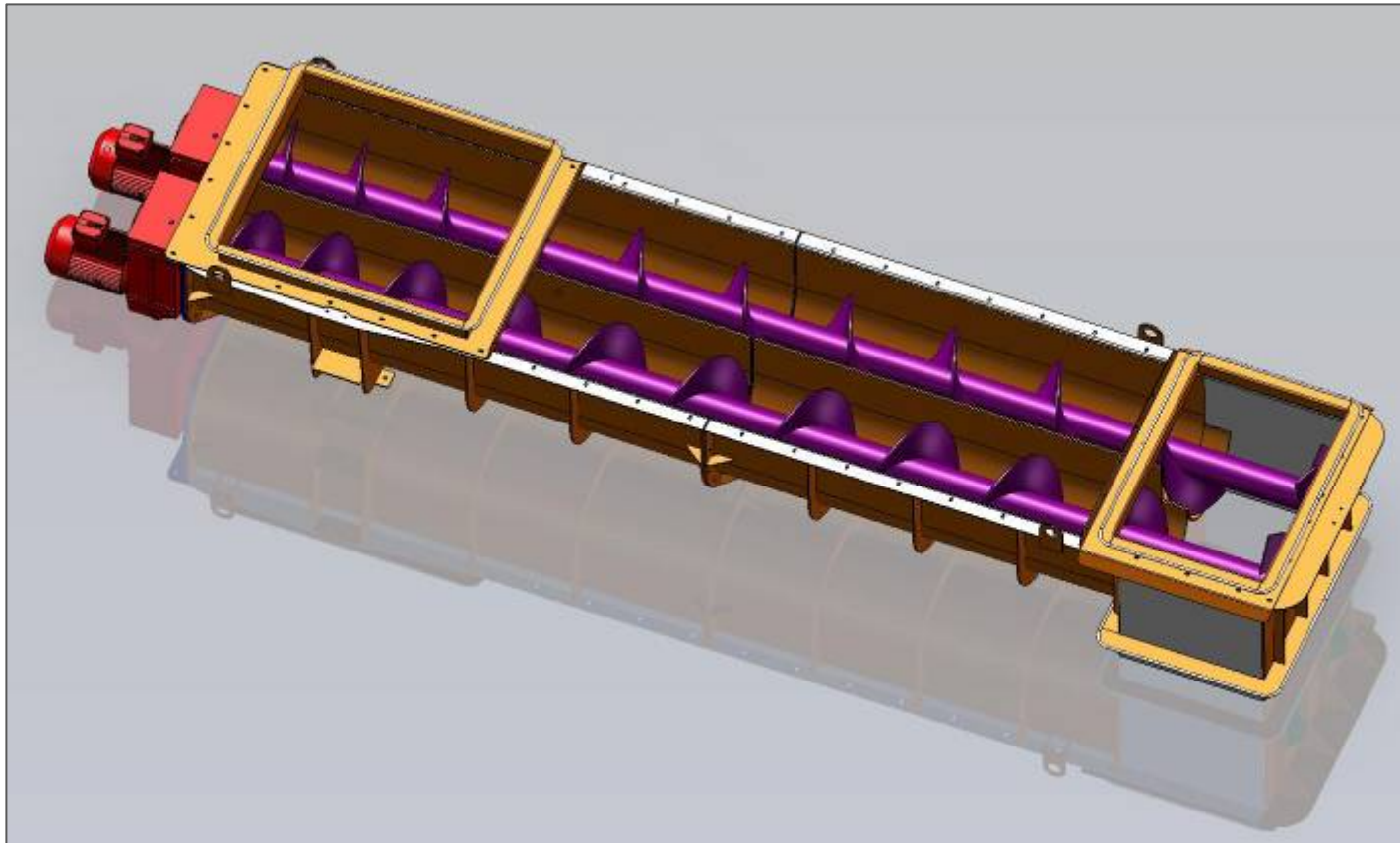

Standard volumetric feeder normally interfaced with feed hopper prior to boiler feed chute.

Volumetric – (Belt)



Standard volumetric belt feeder normally used to extract suitable fuel types from storage and to interface with boiler feed chute.

5

Conclusions and Developments



Conclusions

Biomass handling, how hard can it be ?

Other industries and global markets have successfully handled biomass and other solid alternate fuels for many years

However

- **The materials certainly create challenges that drive extensive design implications far beyond the level that the material descriptions initially suggest**
- **Handling large volumes, typically 3 or 4 x the volume of coal for the same calorific value presents considerable handling difficulties**
- **The transport logistics and fuel availability will drive attempts to keep costs and supply volatility low**

However

- **We have overcome many of the handling hurdles and can now create optimized system designs that are less problematic and flexible enough to cope with variation in fuels and multiple fuel types**
- **We can no longer have to accept or rely on system that are based on agricultural technology. We have technologies that can supply optimized gravimetric fuel feeding at a level equal to those utilized within existing coal fired plants**
- **Unloading systems and handling systems are able to handle multiple fuels reducing the supply pressure and allowing better management of market fluctuation.**

Integrated Fuel Intake and Gravimetric Gasification Feed System

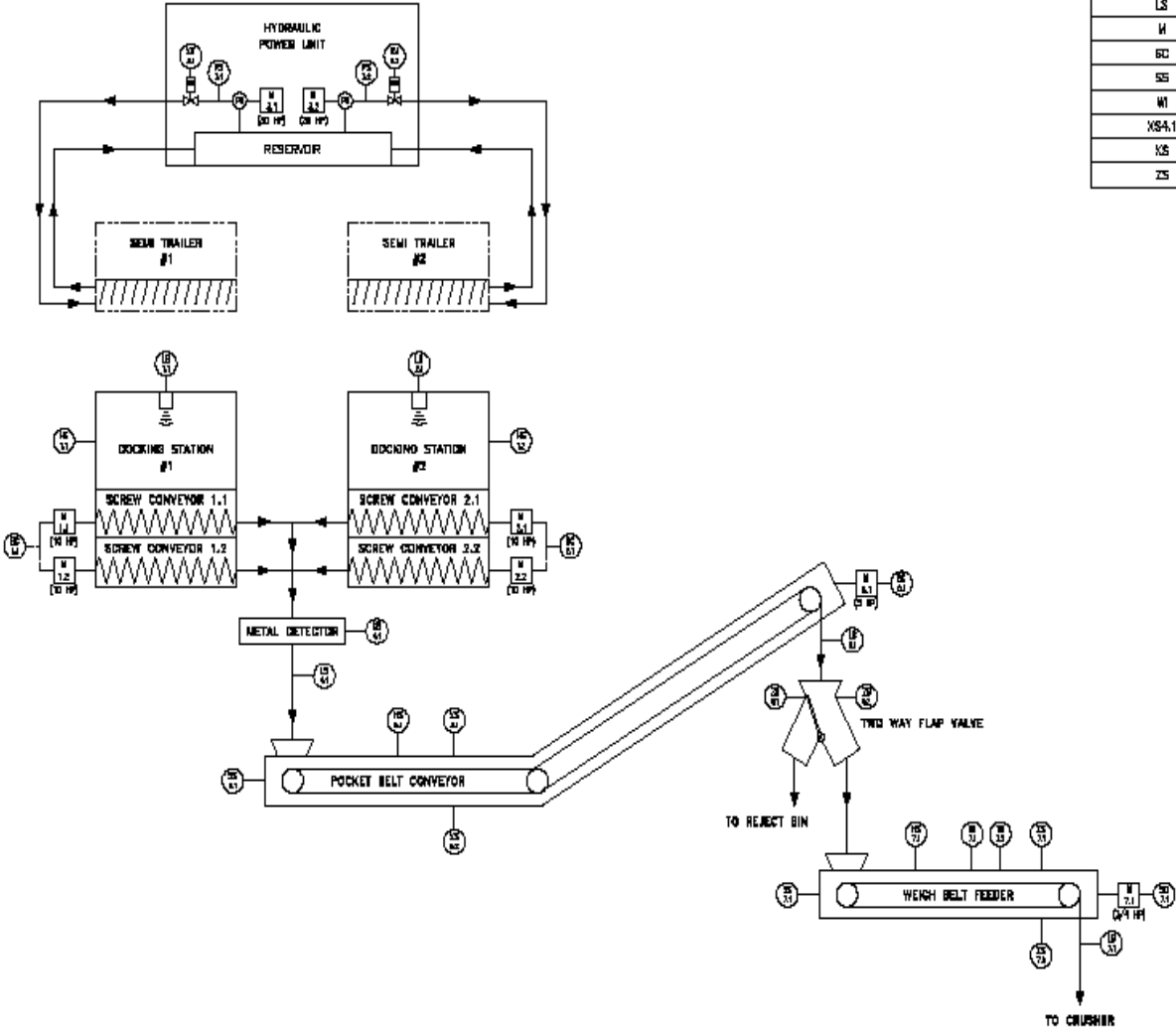

SYMBOL	DESCRIPTION
HS	HAND SWITCH - EMERGENCY STOP
LS1,1,2,1	LEVEL SWITCH - CONTINUOUS LEVEL MONITOR
LS	LEVEL SWITCH - PLUGGED CHUTE
M	MOTOR
SC	SPEED CONTROL - VARIABLE FREQUENCY DRIVE
SS	SPEED SWITCH
WI	WEIGHT INDICATOR - LOAD CELL
XS4.1	SWITCH - METAL DETECTOR
KS	SWITCH - BELT TRACKING
ZS	LIMIT SWITCH

Container Intake and Gravimetric Feeding System schenckprocess

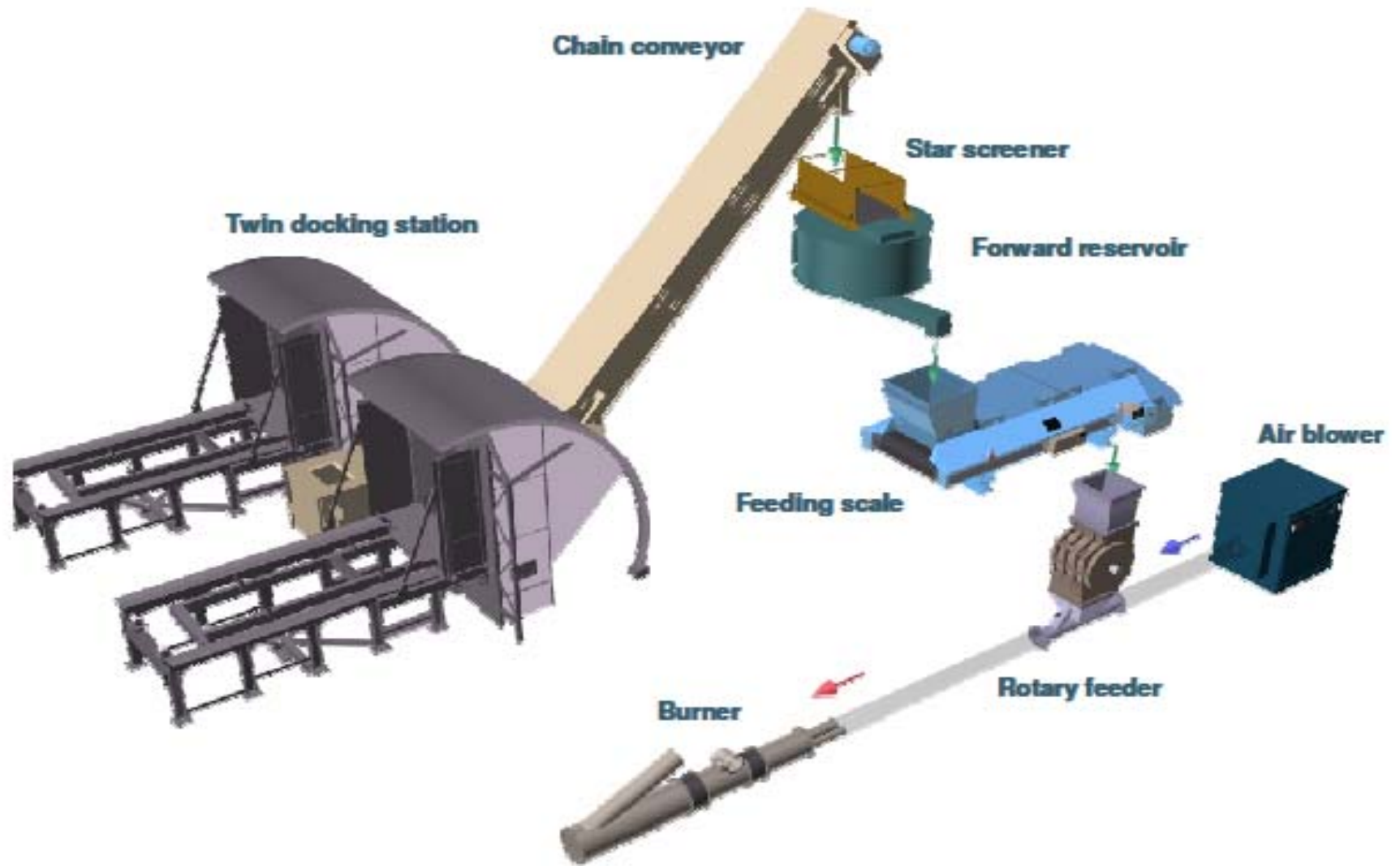

Biomass Gasification System Feeding

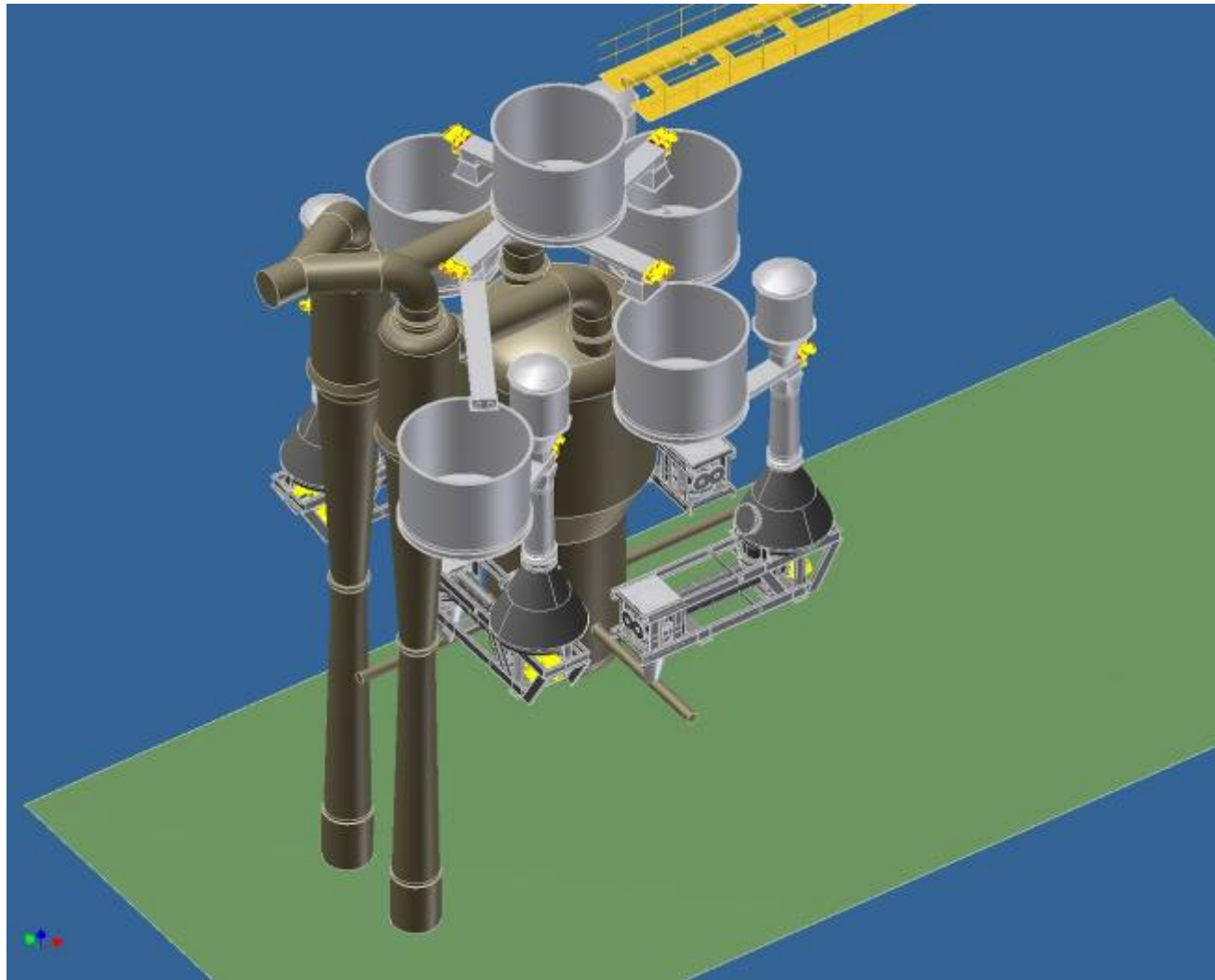

Incorporation of Elemental Analysis



Creating online moisture, BTU and elemental data that can be used to determine fuel quality and optimize system performance

Blending Layout Example

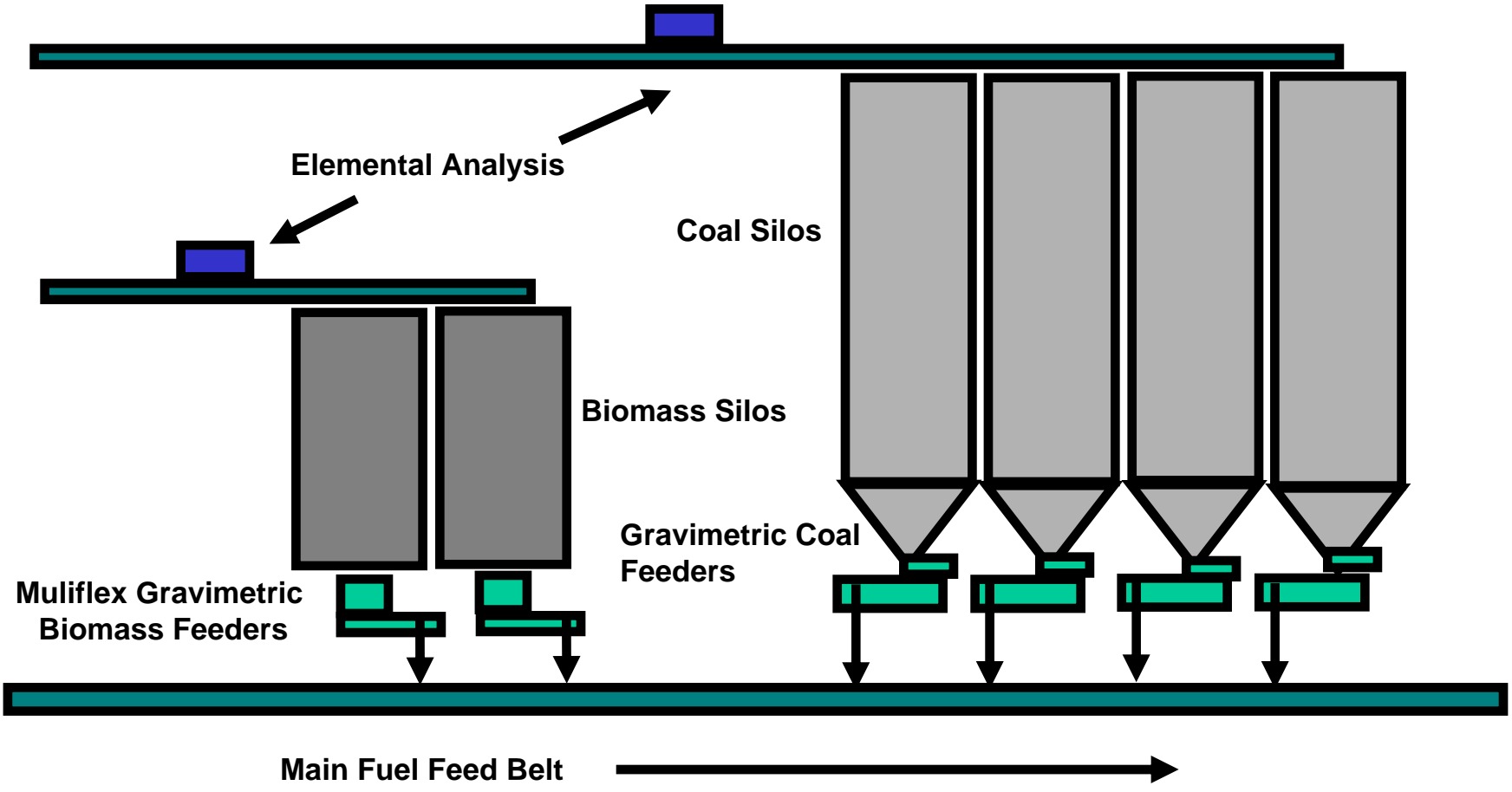

The future could include elemental analysis to determine moisture and BTU value enabling optimized fuel blending and combustion.

Loading of Biomass and Alternative fuels



- **Possibility of conveying directly from production line without need of a storage site**
- **Closed system with minimum dustiness**
- **Minimum 20% shorter loading time**
- **On an average 15% higher loading weight**
- **Material homogenizing during loading**



THANK YOU

1 2 | 5 | 10 | 20 | 40 | 75 | 125 years