

# Worldwide Pollution Control Association

**Duke Energy Seminar**  
**September 3 – 5, 2008**  
**Concord, NC**



Visit our website at [www.wpca.info](http://www.wpca.info)

**W**  
**P**  
**C**  
**A**

# LESSONS LEARNED SCR & SO3

---

Mark Thomas - Duke Energy  
Panelists  
Wayne Whitaker - Duke Energy  
Ken Jeffers – Argillon  
Peter Struckman – E.ON Us  
Sterling Gray - URS

# SCR & SO3 LESSONS LEARNED OVERVIEW

---

- ❑ Impacts of SO3 on SCR operations
- ❑ Experience from Users & Vendors
- ❑ Possible strategies to minimize negative impacts

# SO<sub>3</sub> & ABS Formation

---

- Ammonia Sources
  - Ammonia Injection Grid
  - Ammonia Slip (Unreacted NH<sub>3</sub>)
    - Imbalances in Temp, NO<sub>x</sub>, NH<sub>3</sub>, Flow
    - Deactivated Catalyst
    - Control Problems

# How SO<sub>3</sub> is Formed

In Boiler aprox 1% of SO<sub>2</sub> oxidizes to form SO<sub>3</sub>

In SCR additional 0.75% -to-1.5% of SO<sub>2</sub> oxidizes to form SO<sub>3</sub>. Vanadium in SCR serves as catalyst for this reaction.

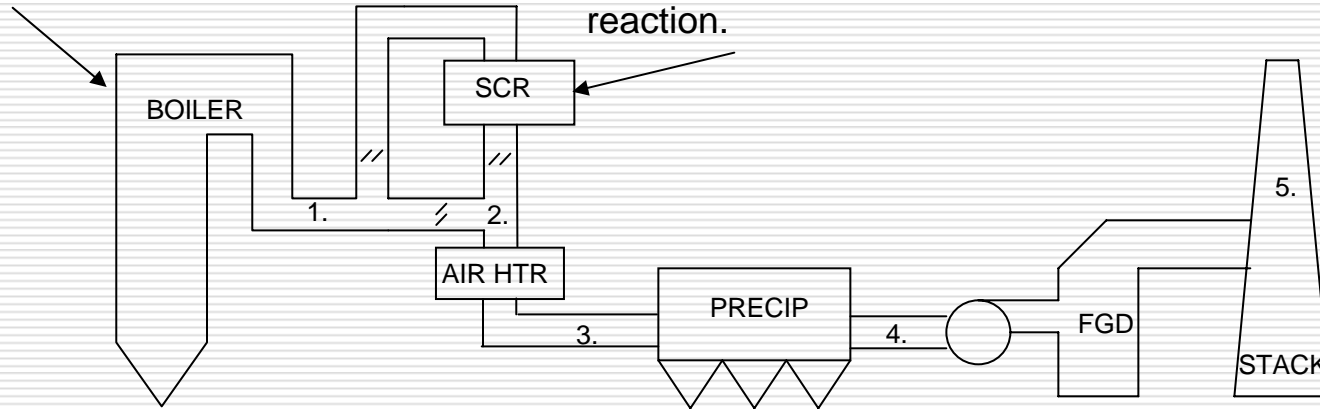

## Physical Forms of SO<sub>3</sub>

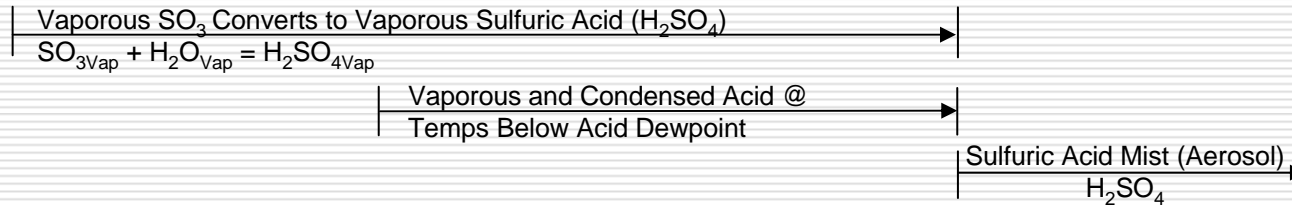

# SO<sub>3</sub>/ABS EFFECTS ON SCR CATALYST

---

- ABS Sublimation in Catalyst Pores
  - A Function of SO<sub>3</sub>, NH<sub>3</sub>, Temp
  - Fills Pores > Reduces Catalyst Activity
  - Requires NH<sub>3</sub> to be cutoff below T<sub>min</sub>
  - T<sub>min</sub> Limits Low Load Operation
  - Operation Below Can Accelerate Deactivation

# SO<sub>3</sub>/ABS EFFECTS ON SCR CATALYST

---

- ❑ SO<sub>3</sub> Off-Gassing During Temp/Load Increase
- ❑ Could result in Transient SO<sub>3</sub> Issues

# SO<sub>3</sub>/ABS EFFECTS ON SCR SYSTEM & ASSOCIATED EQUIPMENT

---

- Ammonia Injection Grid Pluggage



# SO<sub>3</sub>/ABS EFFECTS ON SCR SYSTEM & ASSOCIATED EQUIPMENT

---

- Air Preheater Pluggage & Corrosion



# SO3/ABS EFFECTS ON SCR SYSTEM & ASSOCIATED EQUIPMENT

---

## □ Duct Corrosion



# SO<sub>3</sub>/ABS EFFECTS ON SCR SYSTEM & ASSOCIATED EQUIPMENT

---

## □ Plume Opacity



# SO<sub>3</sub>/ABS Mitigation General

---

- Reagent Injection Systems
  - Magnesium, Sodium, Calcium
  - Very Unit Specific
  - Know Tradeoffs!!
  
- Low SO<sub>2</sub> to SO<sub>3</sub> Oxidation Catalyst
  - Thin Wall Catalyst
  - Vanadium Content/ Formulation
  - Know Tradeoffs!!

# LESSONS LEARNED SCR & SO3

---

QUESTIONS??

---