

Reinhold Environmental Ltd.



2007 NOx Round Table & Expo
Presentation

February 5-6, 2007 in Cincinnati, OH

Low SO₂ Oxidation Catalyst
Impact on Poison
Resistance And Hg
Oxidation
2007 NO_x Round Table

Author: Volker Rummenhohl, Tackticks, LLC

Cincinnati
February 5, 2007

Agenda

- Introduction
- What Are The Problems of High SO_3 Concentrations And What Is Low SO_2 Oxidation?
- NO_x Reaction Mechanism
- Catalyst Poisons
- Mercury Oxidation
- Conclusions



Introduction

➤ Tackticks, LLC

- SCR Consulting and Management
- Founded in 2001
- Located in Durham, NC

➤ FlowTack, LLC

- CFD and Physical Models
- Founded in 2003
- Located in Durham, NC
- 75 % Owned by Tackticks, LLC



Impact of SO₂/SO₃ Conversion Rate

- Coal Types
- Impact On Other Emissions
- Operational Problem Areas



Relevant Coal Types

- High Sulfur Bituminous Coal, Pet Coke, Oil
 - Operational Issues, Visible Plume
- Low Sulfur Bituminous Coal
 - Visible Plume
- Sub Bituminous Coal (PRB)
 - Mercury Reduction



Impact of SO₂/SO₃ Conversion Rate On Emissions

- SO₃
 - New Source Performance
- Opacity
 - SO₃ Becomes visible at concentrations of 5 to 8 PPM depending on ambient conditions
- Mercury
 - SO₃ reduces mercury adsorption on activated carbon



Problem Areas

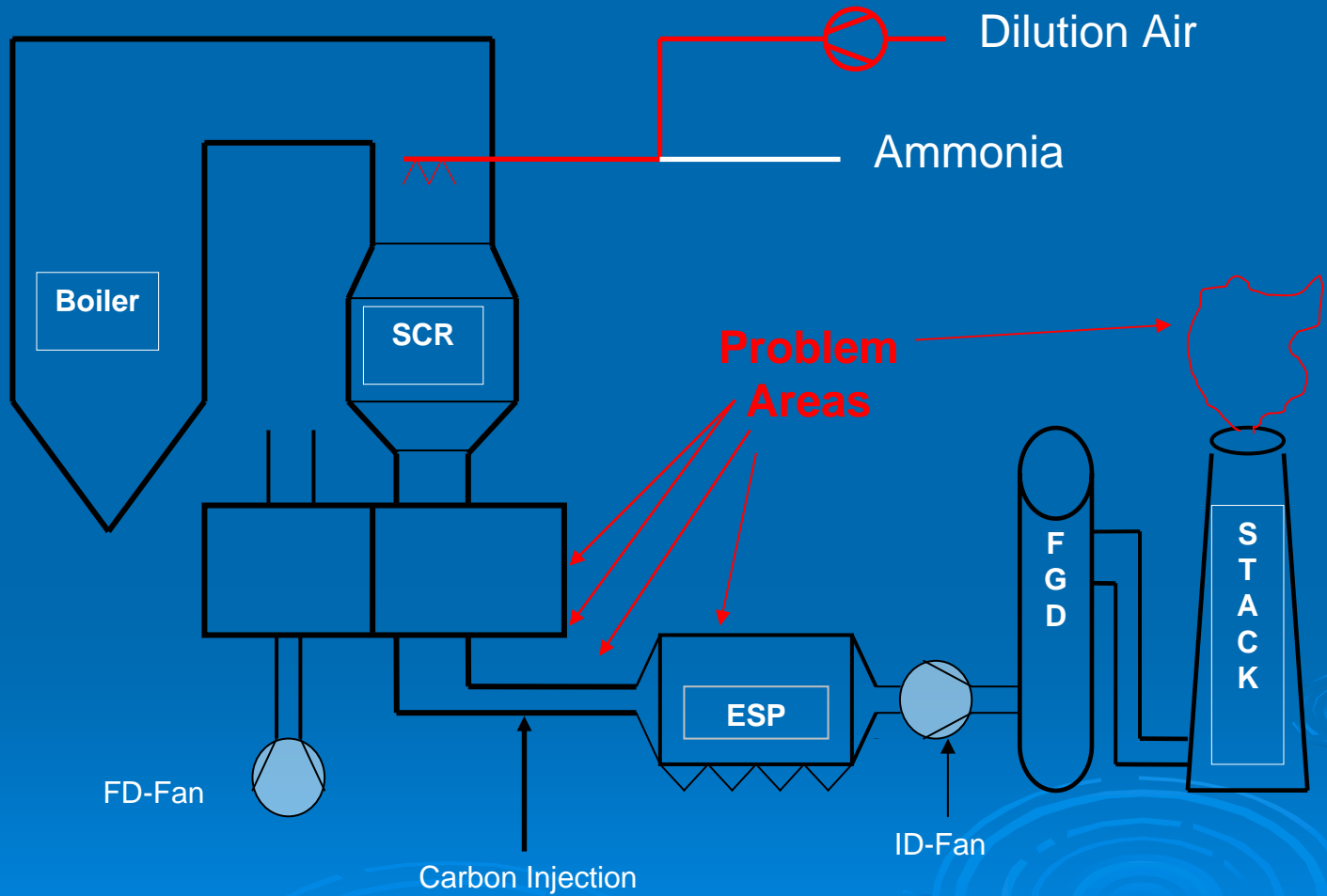

Operational Issues

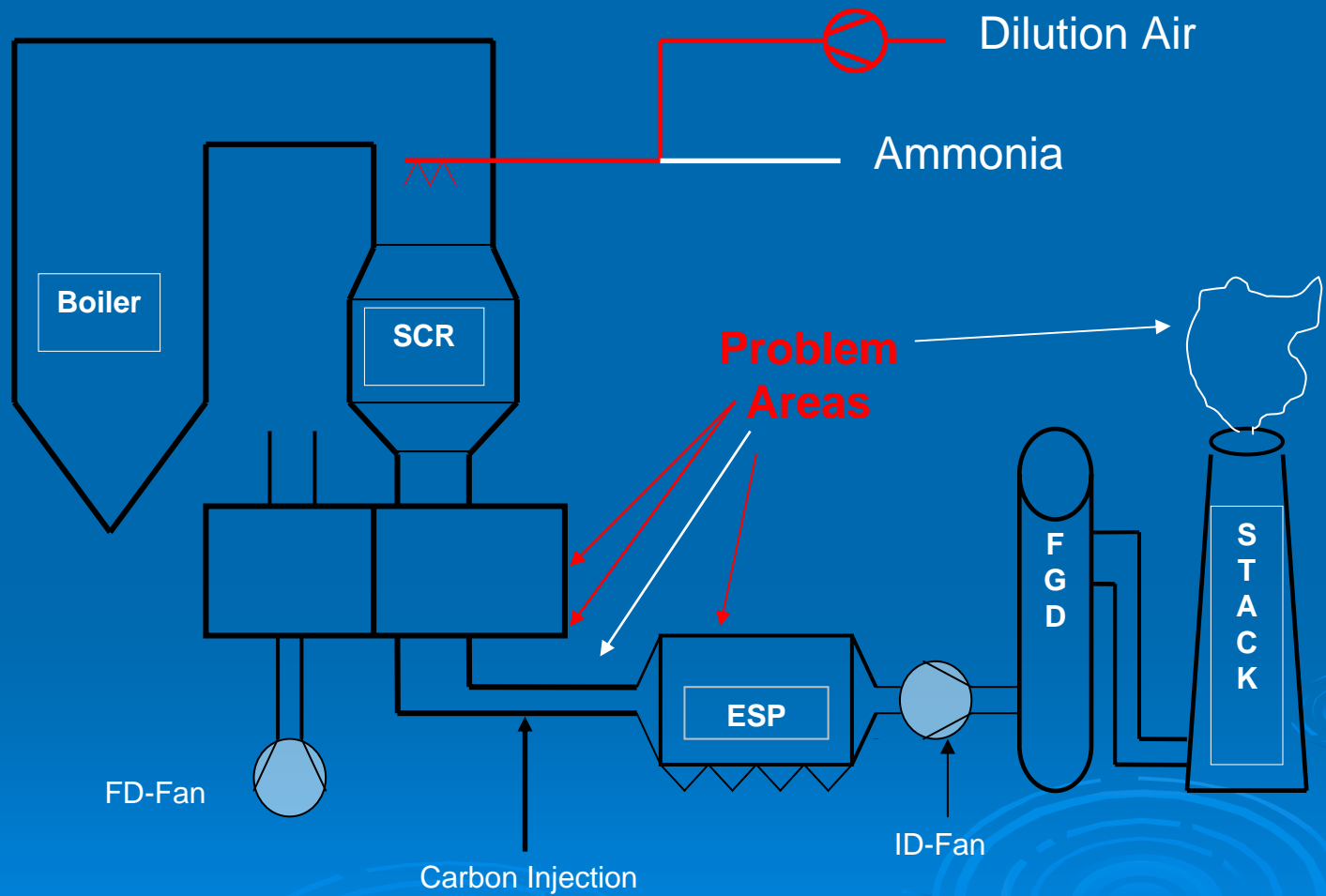

SCR System Process Reactions

Undesired Reactions/Implications:



- Ammonia Slip From Process Reacts With SO_3 From the Boiler and the Catalyst to Form Ammonium Bisulfate
- Ammonium Bisulfate Can Precipitate at Intermediate Basket Levels of the Air Heater Leading to Plugging
- SO_3 Can Condense on the Cold End Layers



Air Heater Issues

➤ Ammonium Bi Sulfate Deposition

< 480 F

Temperature Range Depends on SO_3 and NH_3
Concentration

➤ Cold End Plugging Due To Condensed Sulfuric Acid

< 280 F

Temperature Range Depends on SO_3 and Moisture
Concentration

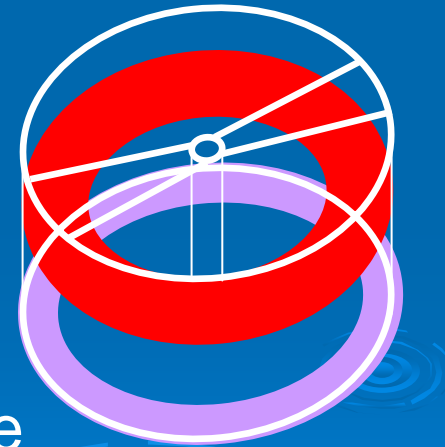

Air Heater Issues

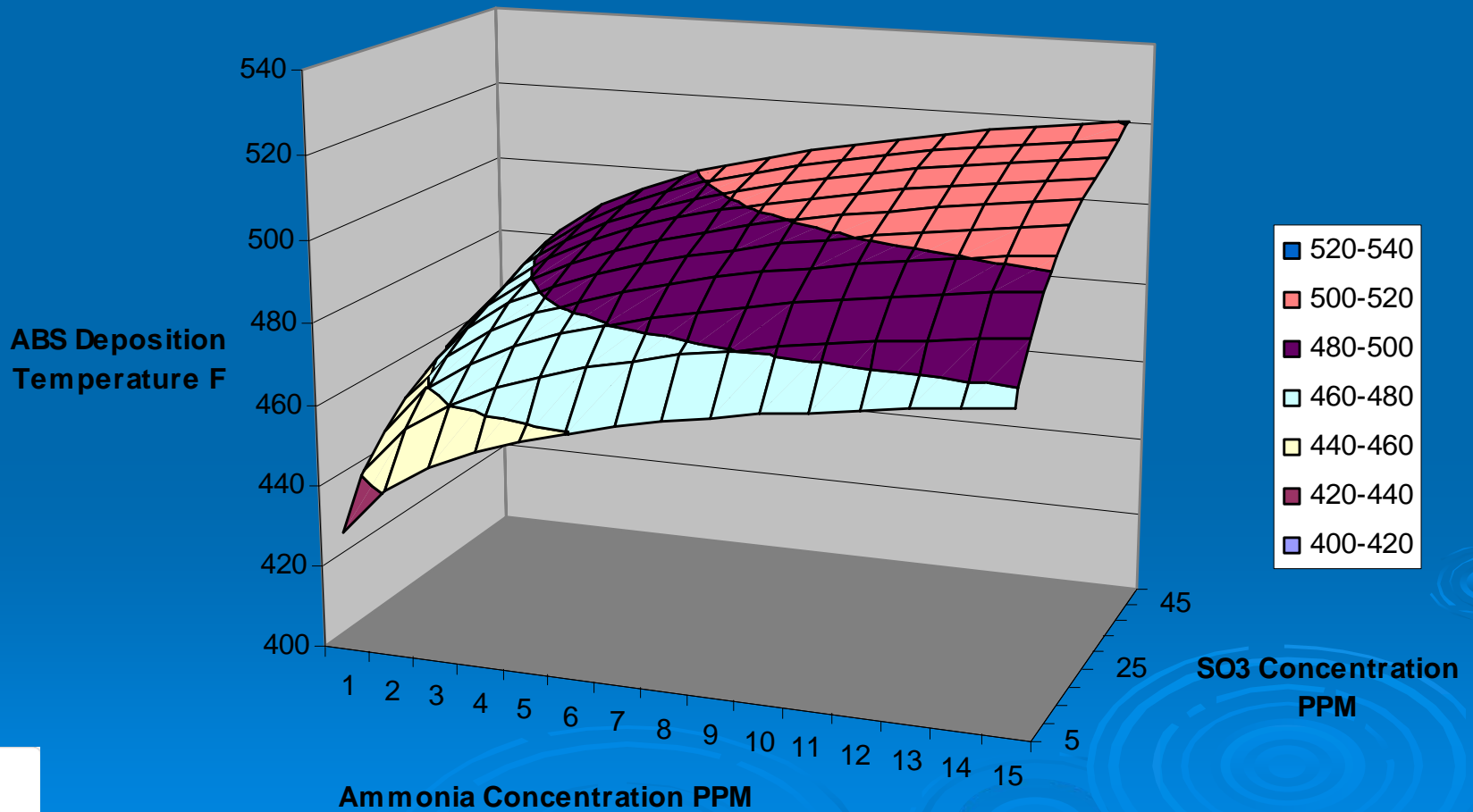

ABS Deposition on Air Heater Difference of Concentrations



Acid Dew Point

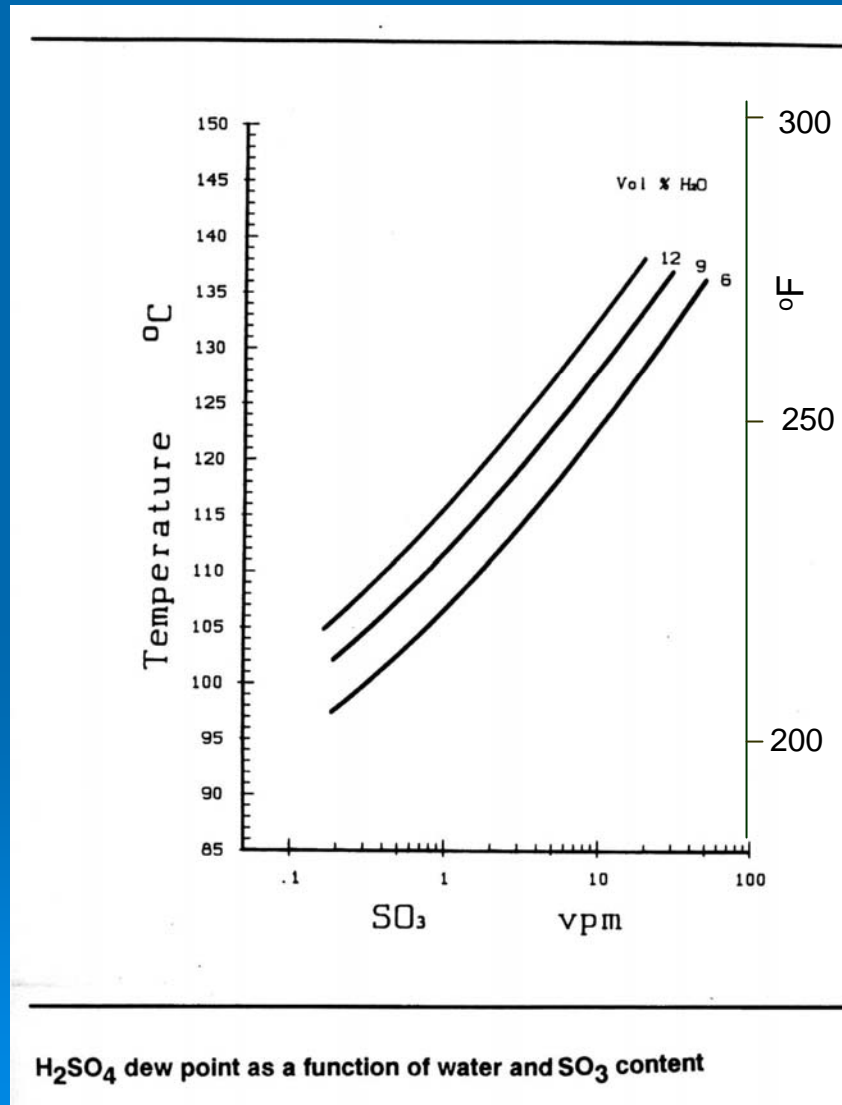

H₂SO₄ dew point as a function of water and SO₃ content



Mercury

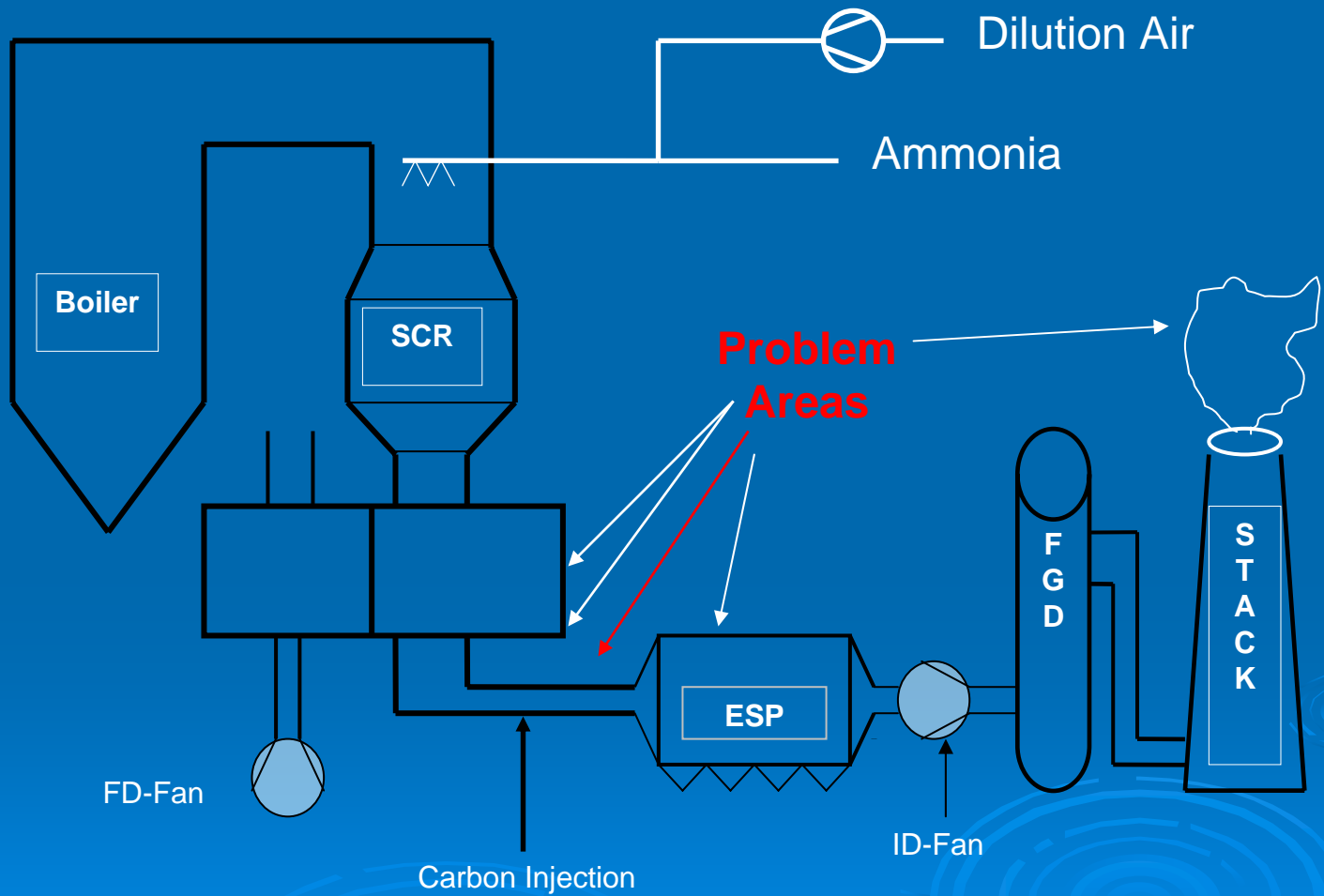

Mercury Adsorption

- Carbon Adsorbs:
 - Acid Gases SO_3 , HCl , HF
 - Mercury
 - Dioxins/ Furanes



Opacity

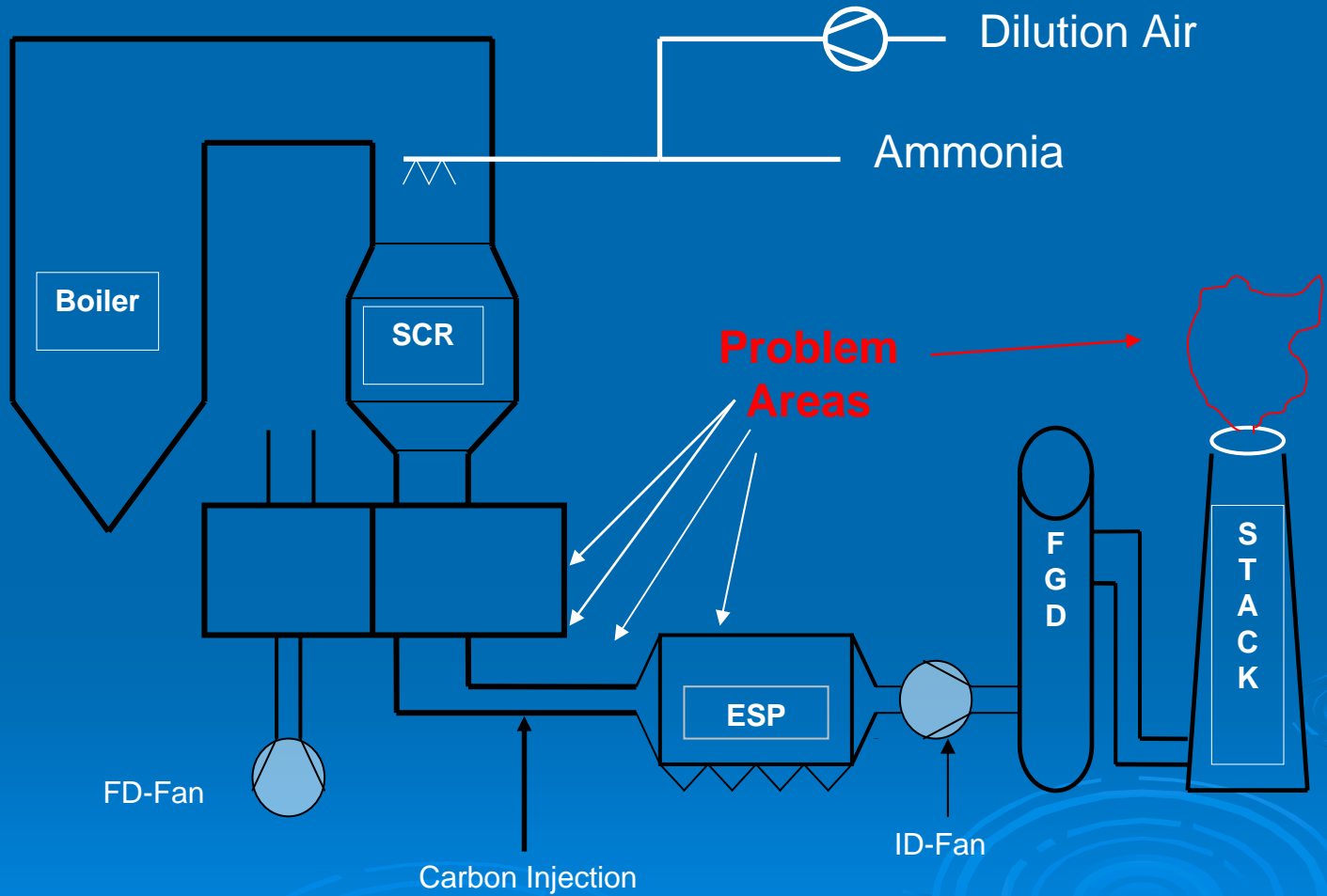

SO₃ Concentration In The Flue Gas Path

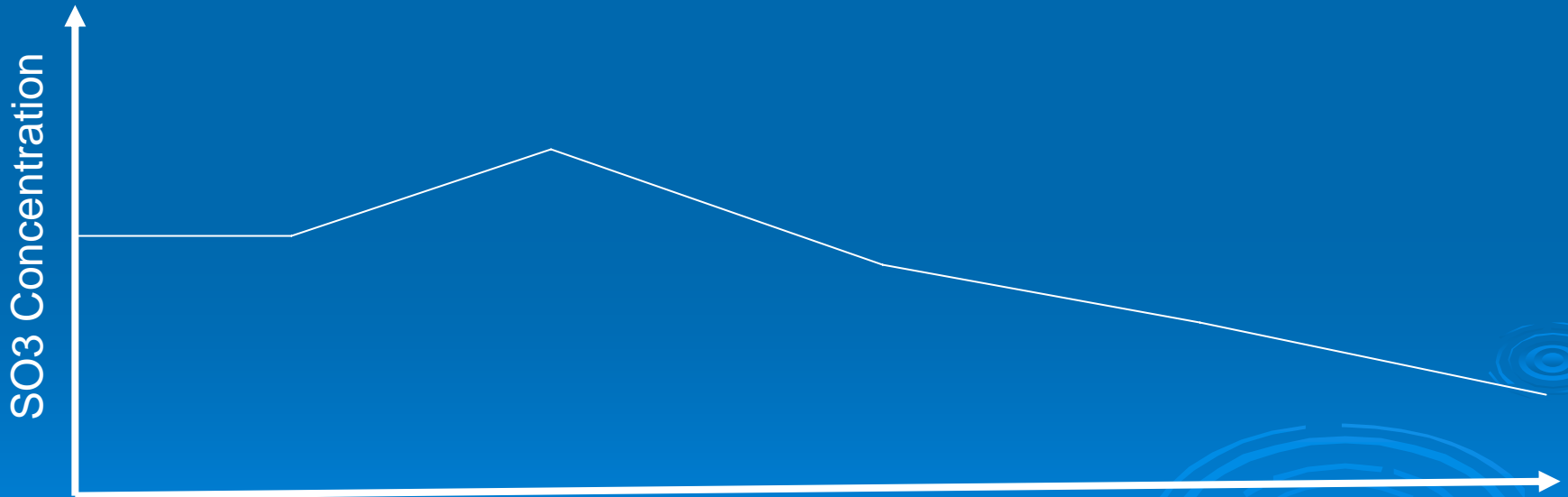

SO₃ Concentration depends on fuel and equipment



Fuel Summary

- High Sulfur Bituminous Coal
 - Air Heater Ammonium Bi Sulfate Plugging
 - Air Heater Cold End Condensation, Plugging and Corrosion
 - Corrosion of Downstream Equipment
 - Plume
- Low Sulfur Bituminous Coal
 - Visible Plume at SO_3 Concentrations of Five to Eight PPM, Depending on Ambient Conditions
- Sub Bituminous Coal (PRB)
 - Mercury Reduction With Activated Carbon



What Is Low
 SO_2/SO_3 Conversion Rate?



Arrhenius Equation

➤ $k = A \exp (Ea/RT)$

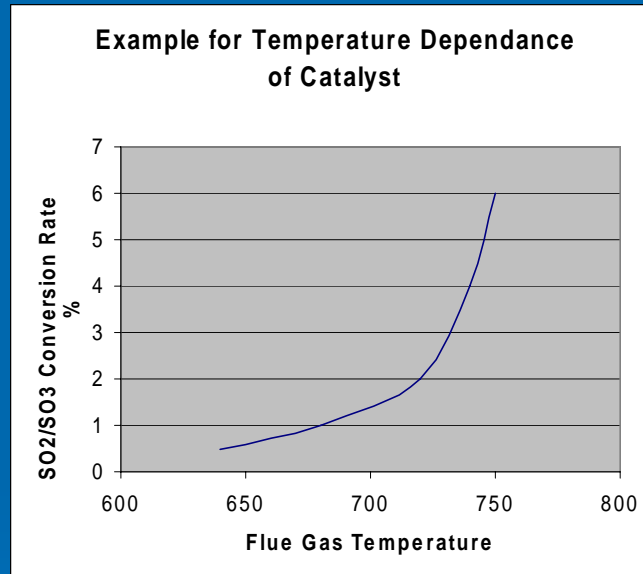

- *Temperature Range at Economizer Outlet of Coal Fired Boilers is approx. 600 – 800 F*



SO₂/SO₃ Conversion Rate Example 1

- 3 – 3.5 % Sulfur Coal
- 2800 – 3300 PPM of SO₂
- Temperature Range @ Full Load 680 to 740 Degree F
- Conversion Rate .5 % @ 740 F = Max.
16.5 PPM SO₃ Additional
- Not Measurable @ 680 F



SO₂/SO₃ Conversion Rate Example 2

- 3 – 3.5 % Sulfur Coal
- 2800 – 3300 PPM of SO₂
- Temperature Range @ Full Load 680 to 740 Degree F
- Conversion Rate 1 % @ 680 F
- Max. 132 PPM SO₃ Additional @ 740 F
- 33 PPM @ 680 F



NO_x Reaction Mechanism



Chemical Reactions On SCR Catalyst

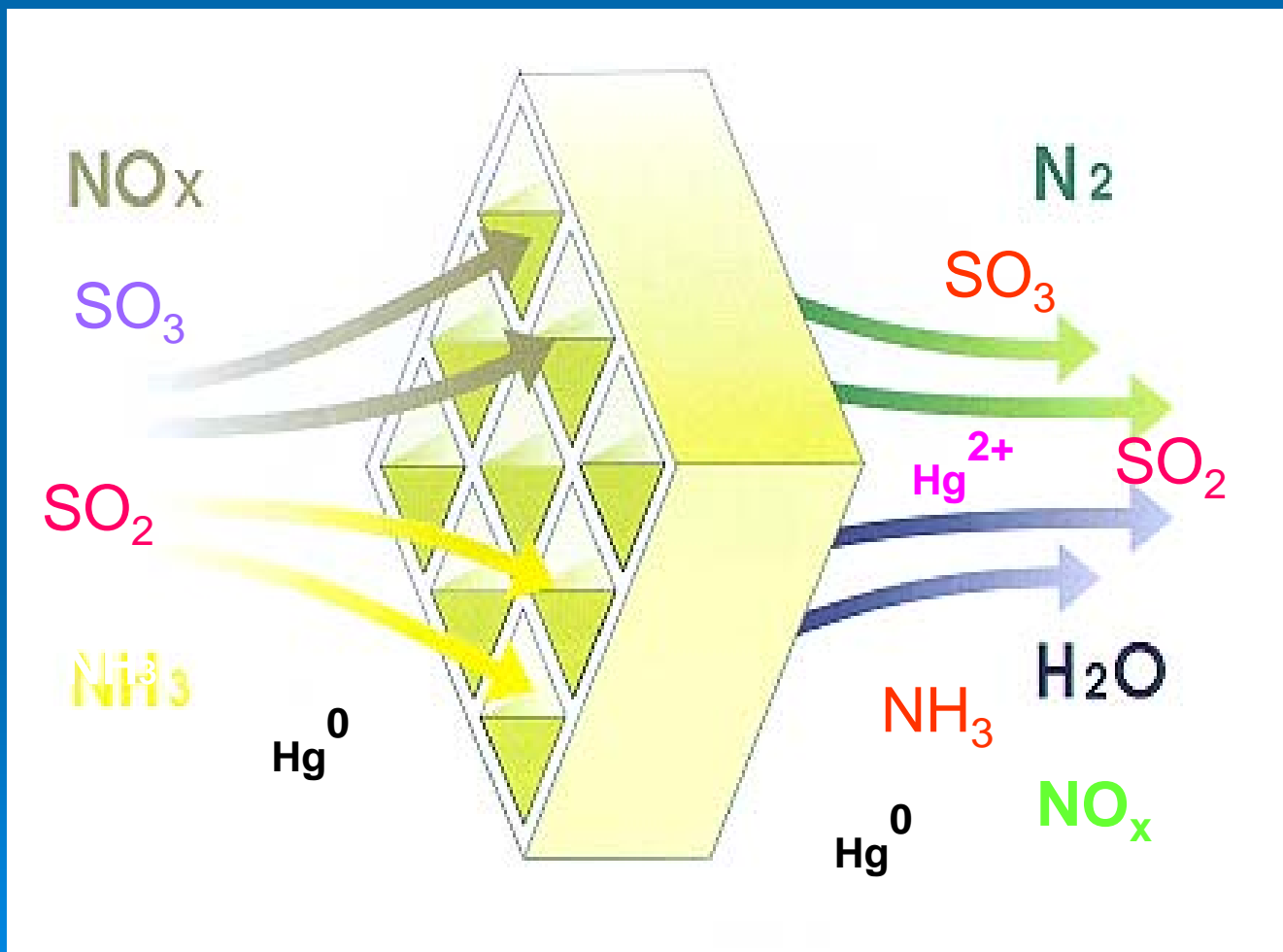

SCR Process Chemistry

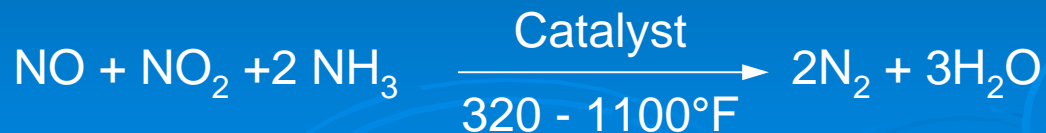
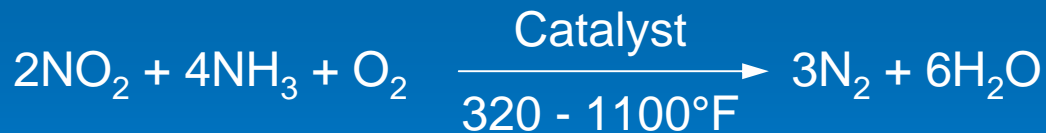
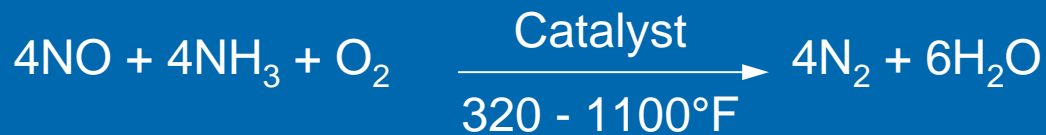
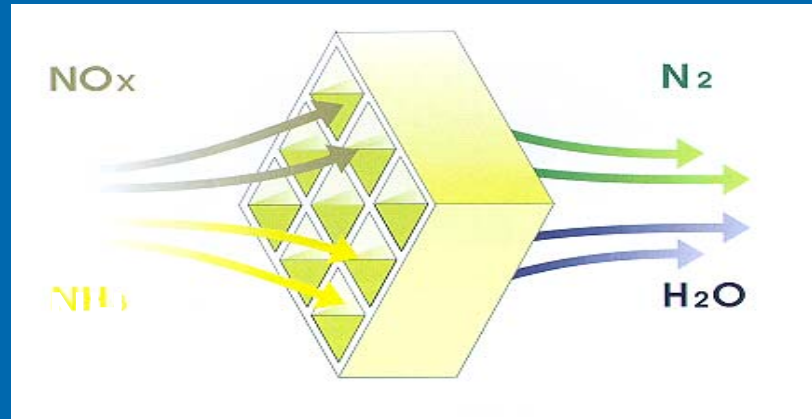

Catalyst Material

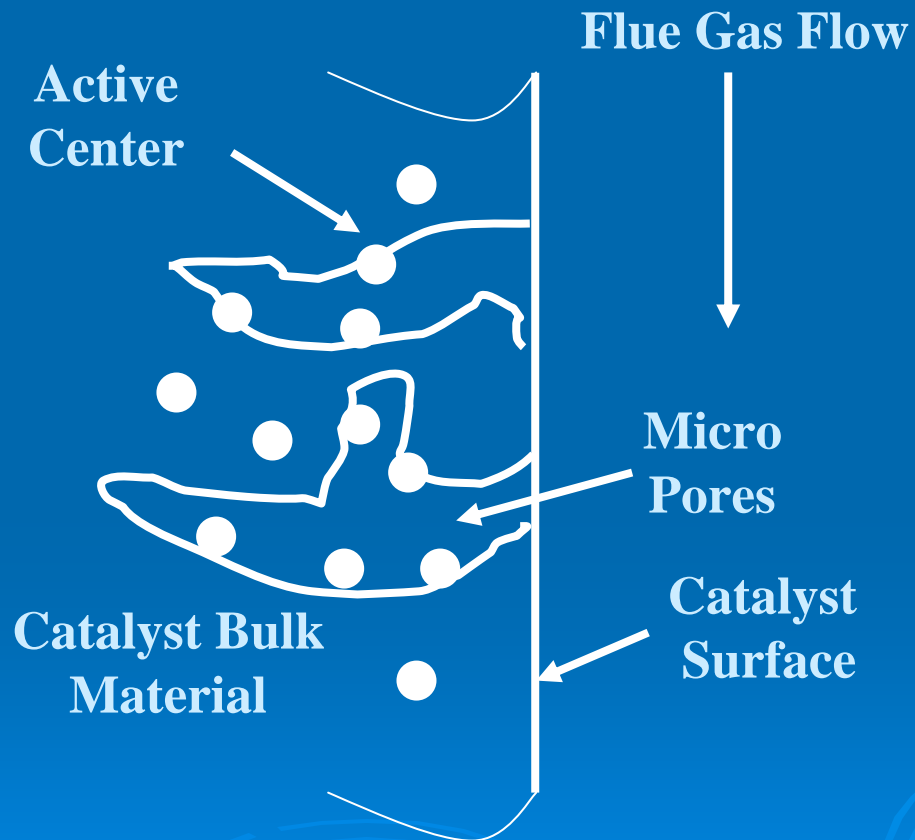

Reaction Mechanism Ammonia Adsorption

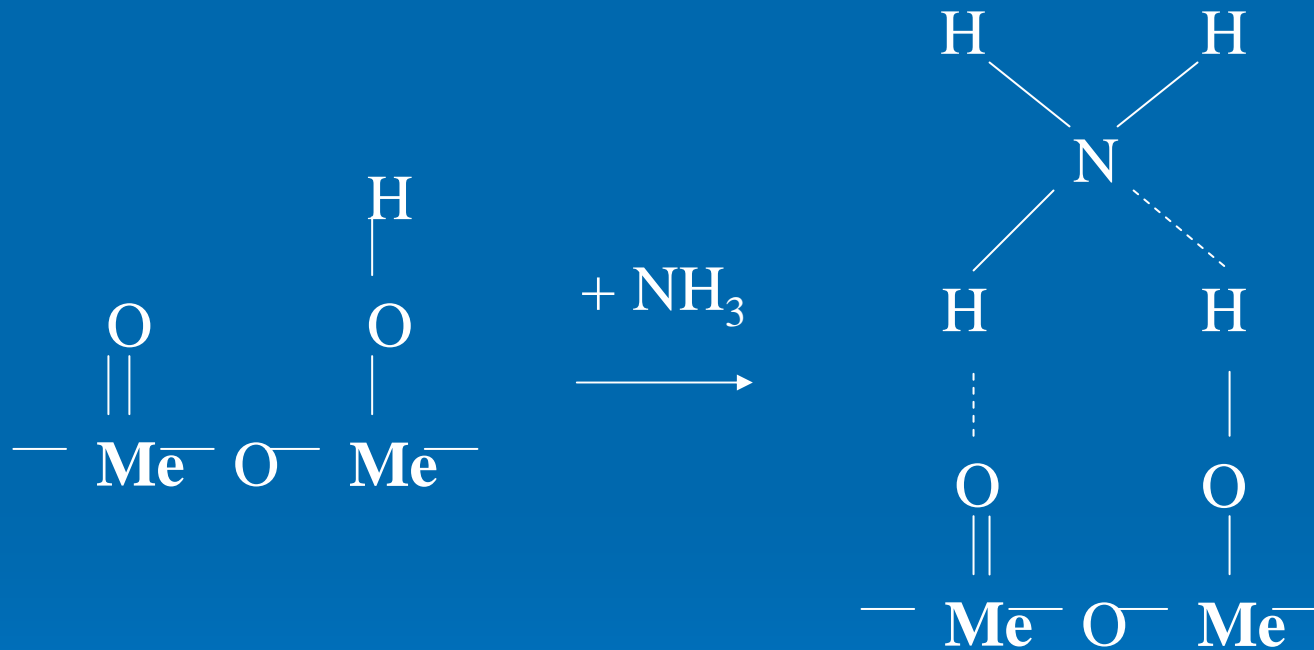

Reaction Mechanism

Reaction Of NO_x and NH_3

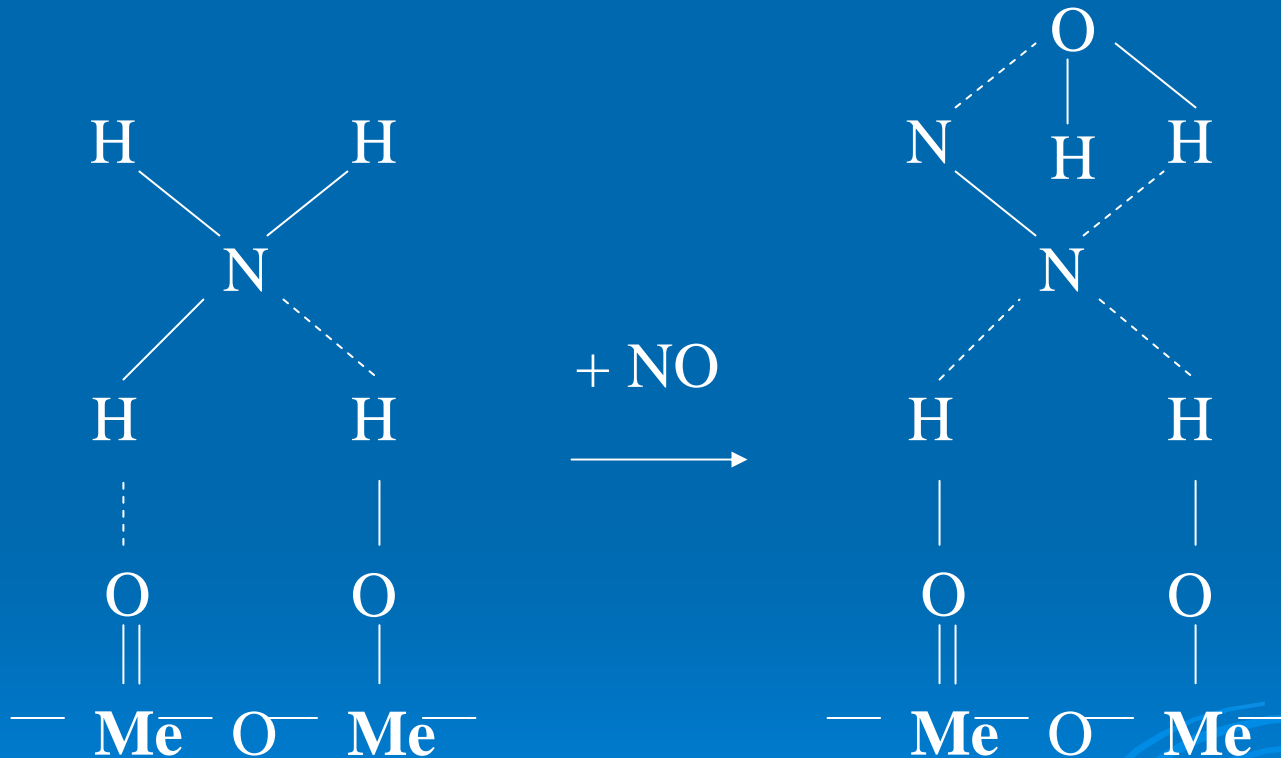

Reaction Mechanism

Desorption of N₂ and H₂O

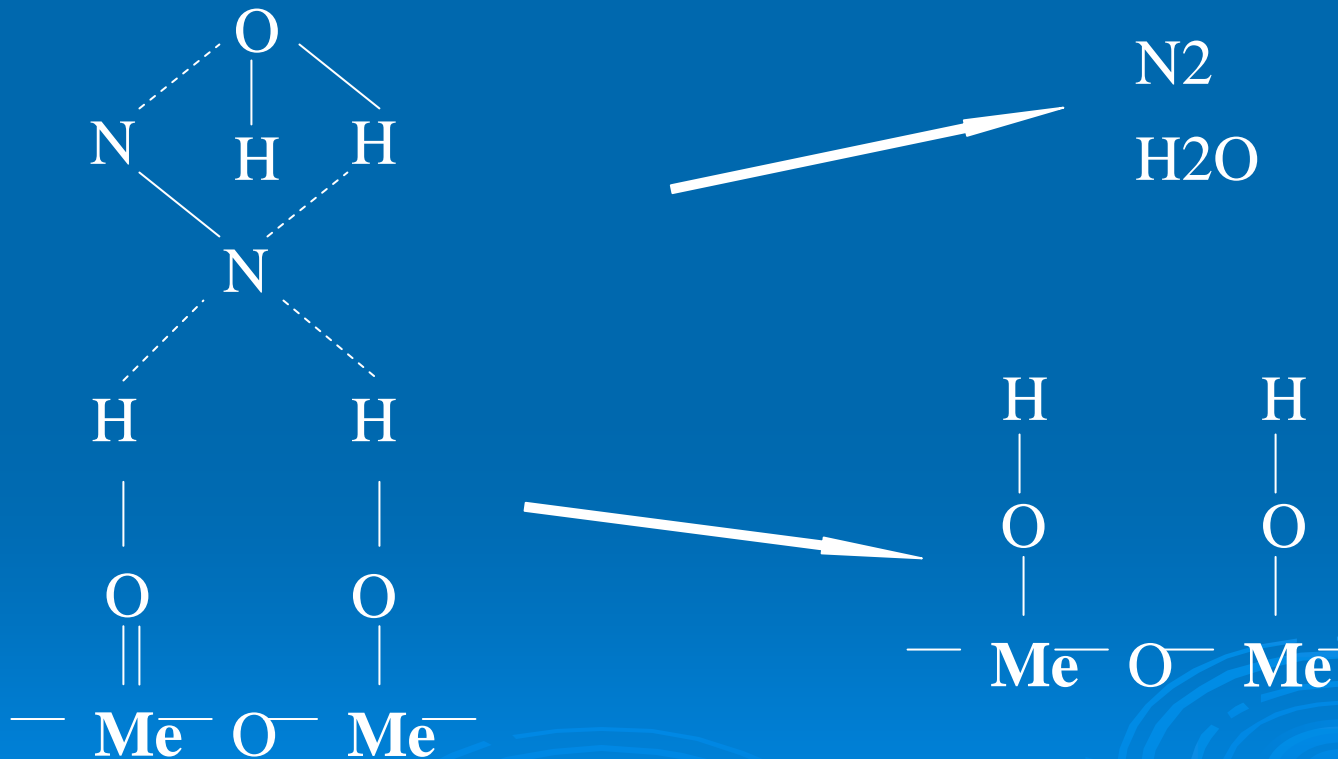

Reaction Mechanism Regeneration

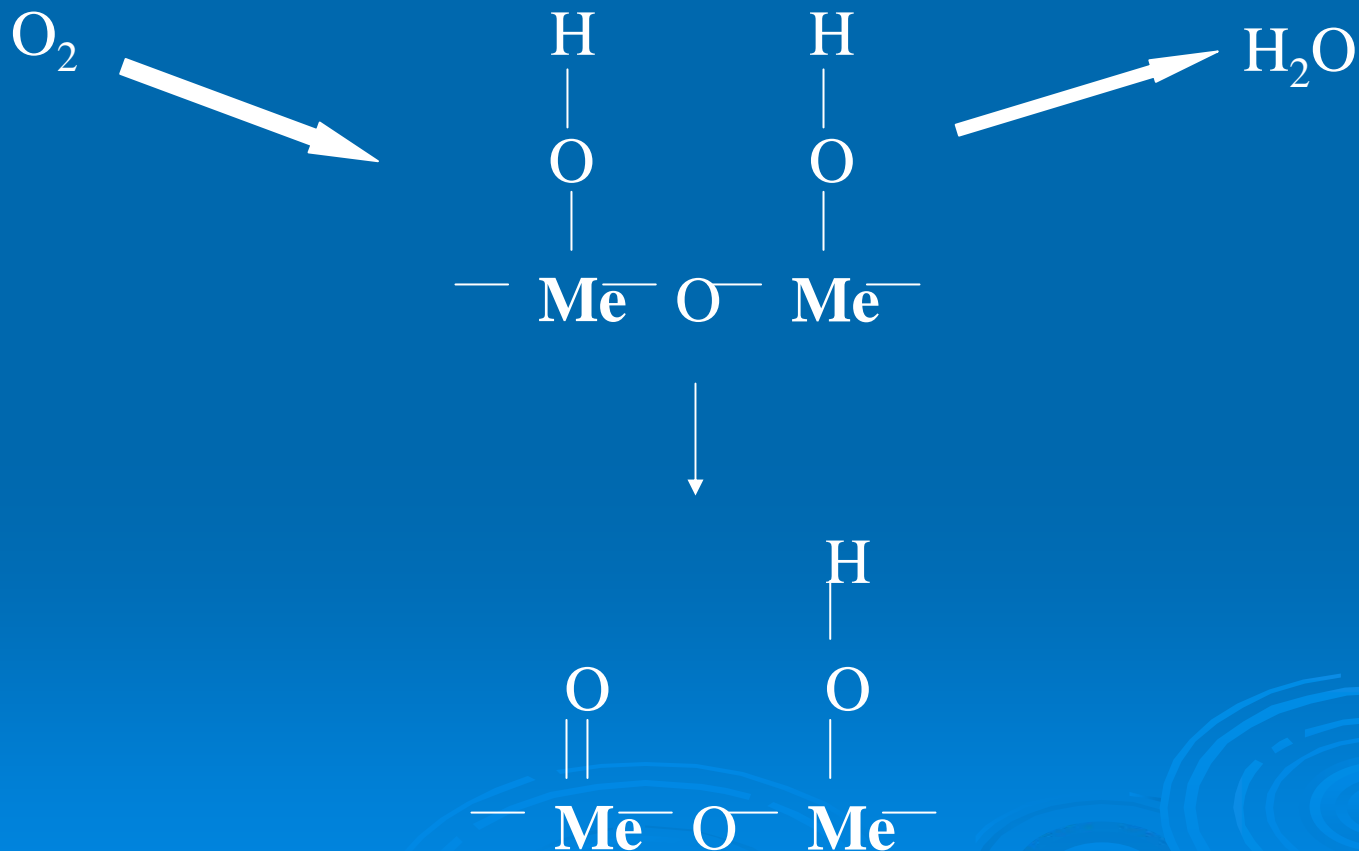

Catalyst Poisons



What can poison the catalyst?

- The most common elements found in coal, oil, or fuel additives that can poison the catalyst material by inerting catalyst material sites:
 - Sodium , Na
 - Lead, Pb
 - Potassium, K
 - Zinc, Zn
 - Arsenic, As
 - Phosphorus



Arsenic Poisoning

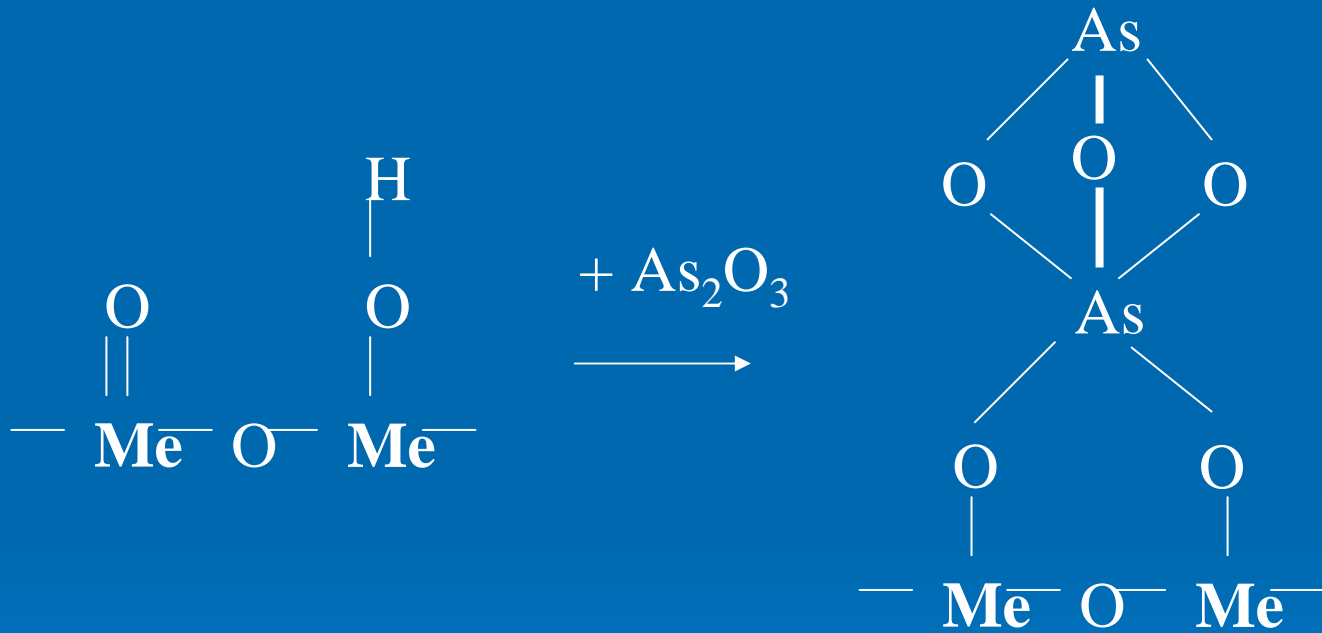

Catalyst Deactivation

- Arsenic Reduces the Activity of Catalyst Through Reaction With Active Centers
- Reaction Product is Permanent
- Active Centers Are Not Available for NO_x Reduction



Catalyst Deactivation

- Arsenic in Solid Form Does not React with Catalyst Components
- Gaseous Arsenic is Formed in the Furnace as As_2O_3
- Arsenic in a Liquid Solution Can Penetrate the Catalyst



History of Arsenic in SCR Systems

Fly Ash Recirculation

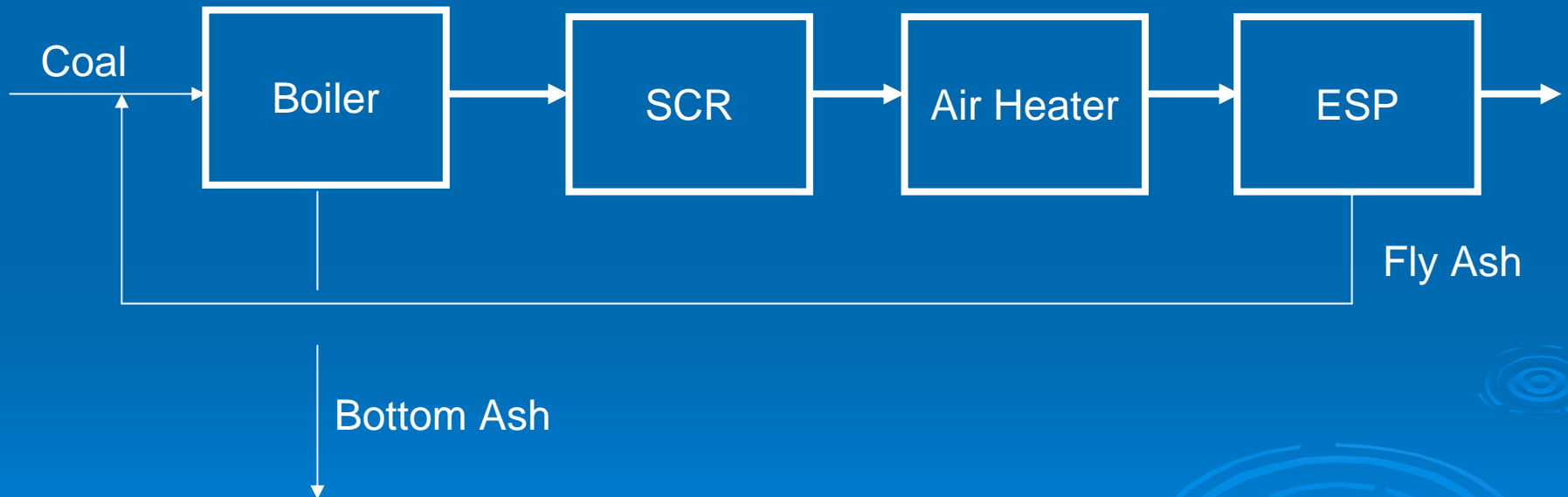

Arsenic VS Ash Recirculation

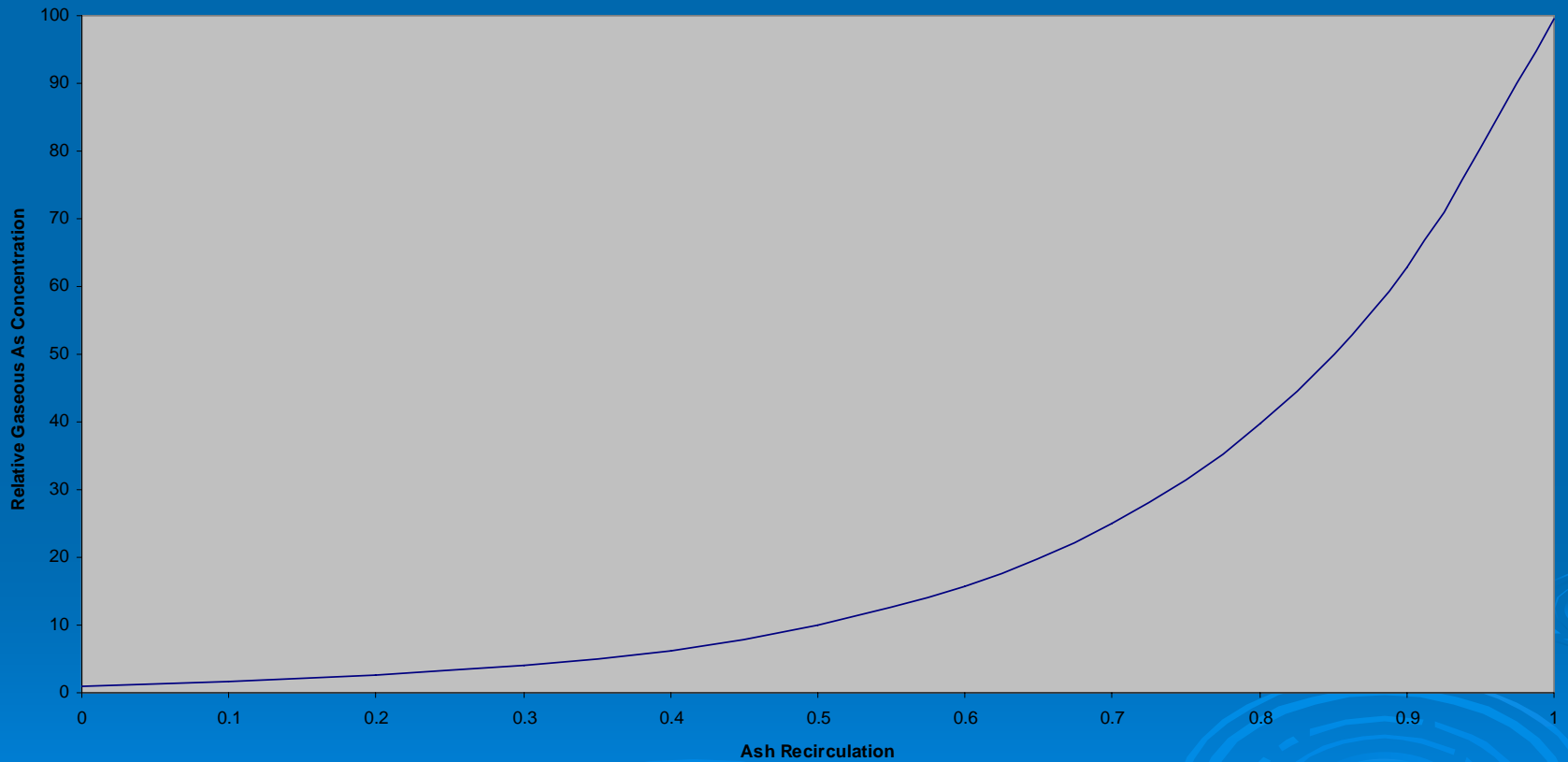

Catalyst Deactivation

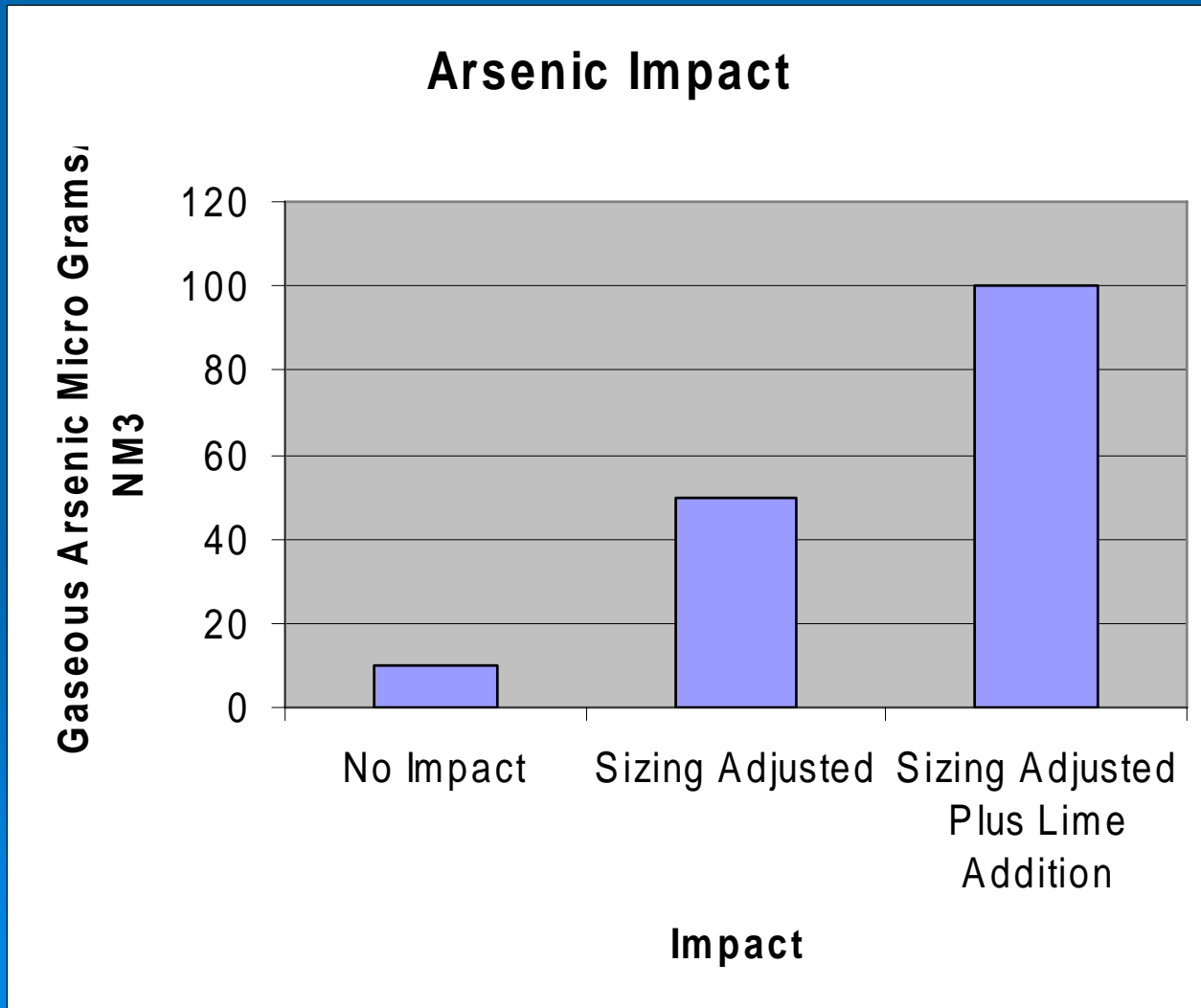

Catalyst Deactivation

➤ Example

- 30 PPM by Weight in Coal = 3850 Micro Grams per NM3 in Flue Gas if All Arsenic in the Coal Would be Converted to Gaseous Arsenic at SCR Temperature



Arsenic Deactivation

- The amount of Gaseous Arsenic at the Catalyst Inlet Depends on:
 - The Arsenic Concentration in the Coal
 - The Calcium Concentration in the Coal
 - The Chlorine Concentration in the Coal
 - The Type of Burner. The Reducing Atmosphere of a Low NO_x Burner Increases the Amount of Gaseous Arsenic
 - Excess Air
 - Unknowns



Arsenic Chloride

Chlorine helps in the case of mercury removal,
But also forms gaseous arsenic chloride

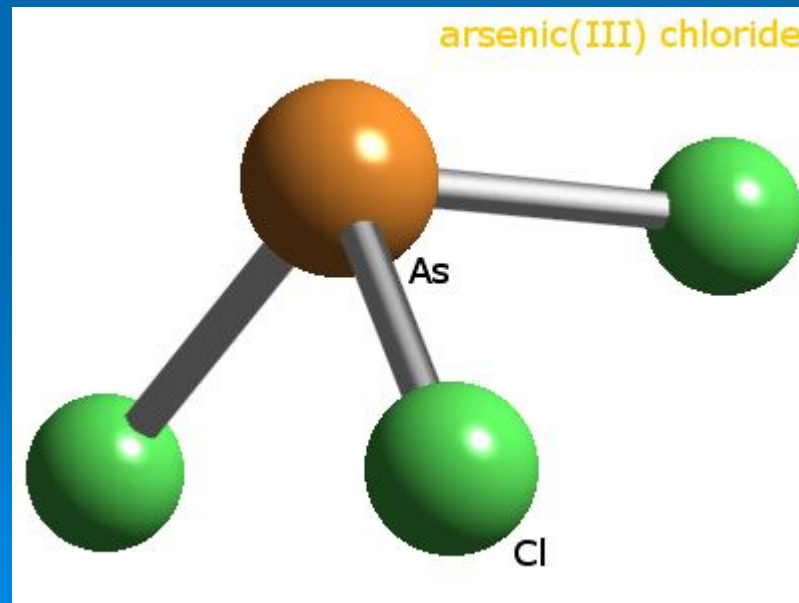

Remedy

- Calcium Addition to the Coal or Injection Into the Furnace Can Reduce the Gaseous Arsenic Concentration
- Limiting Factors
 - Liquid Fusion Point of the Ash
 - Gypsum Blinding of the Catalyst



Arsenic And Conversion Rate

- Arsenic Occupies Active Centers
- The More Active Centers In the Catalyst, The Smaller Is Impact of Arsenic
- The More Active Centers The Higher Is The SO_2/SO_3 Conversion Rate
- The Result Is The Development of New Catalyst



Arsenic Distribution in Catalyst

Typical Concentration in Flow Direction

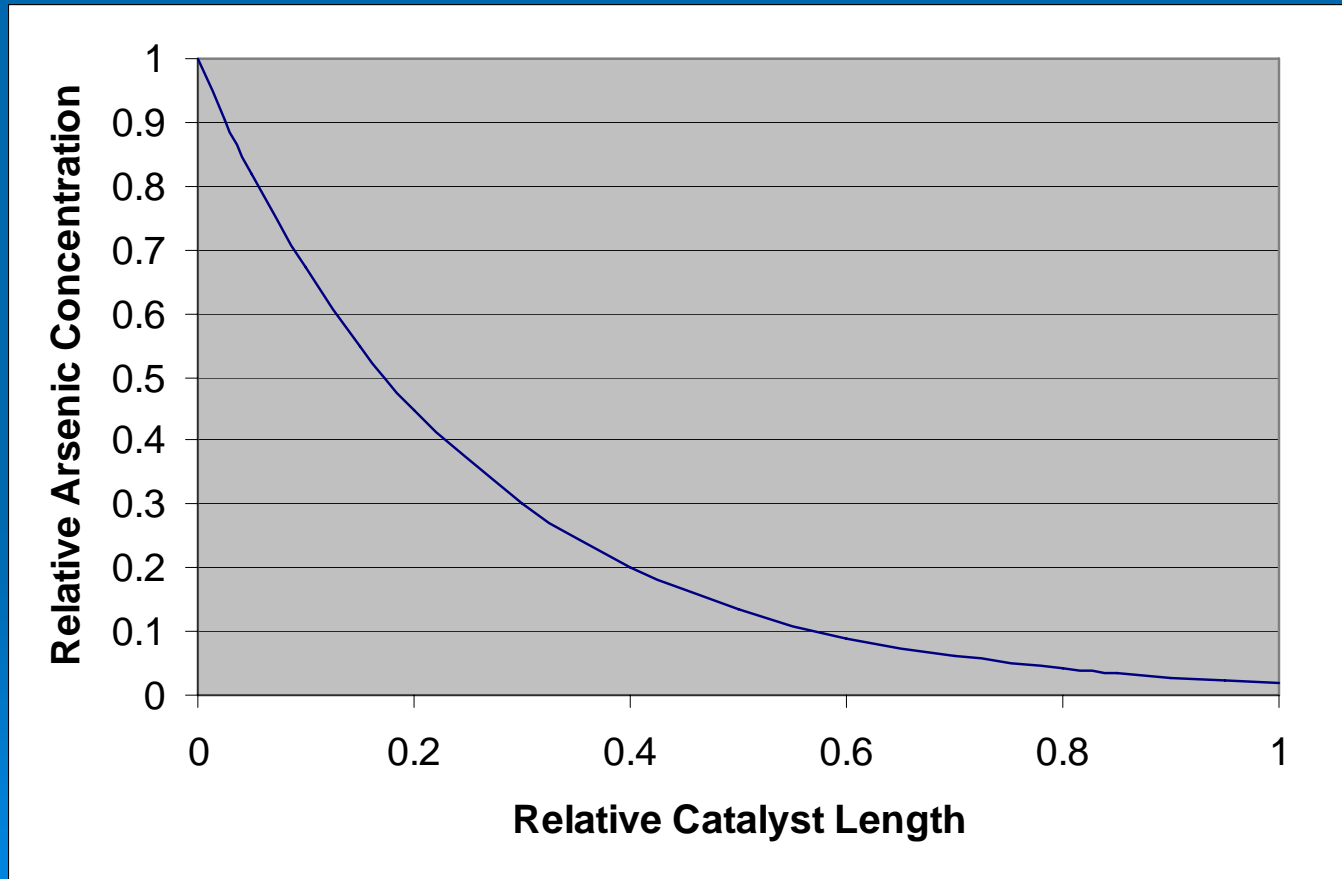

Arsenic Distribution in Catalyst

Typical Concentration in Catalyst Material

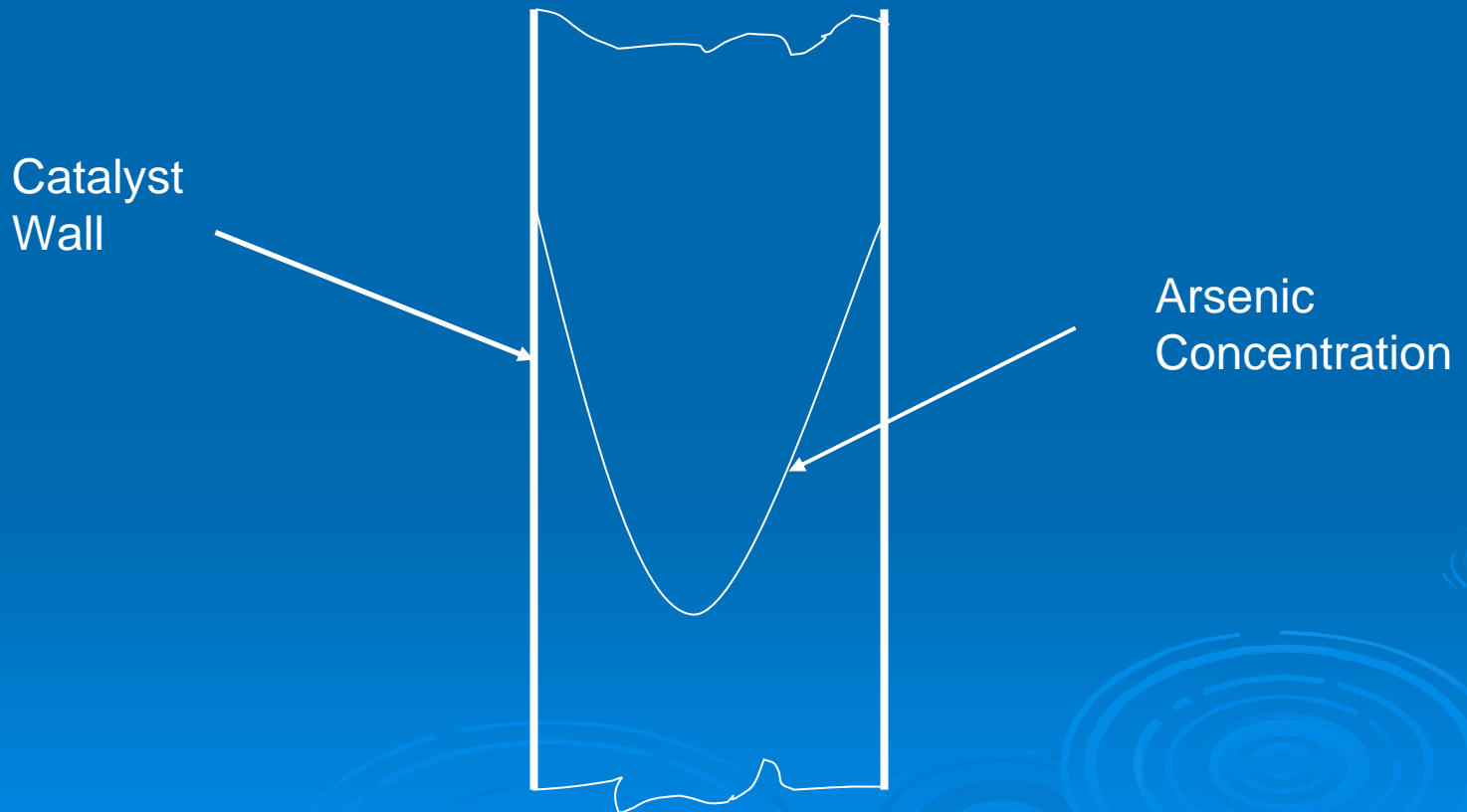

Earth Metal Poisoning

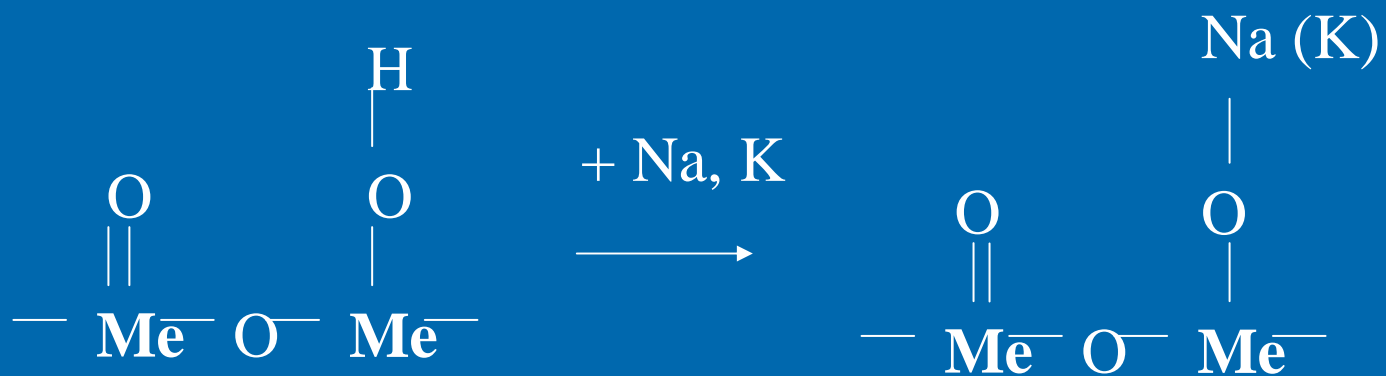

Mercury



Mercury

- Adsorption/ Desorption
- SO₃ Impact
- SO₂ Impact
- NO Impact
- Hg species
- Unburned Carbon



Mercury Fundamentals

- Hg Species: elemental Hg^0 , Ionic Hg^{2+} , on particles Hg^p
- Hg^0 cannot be removed in scrubbers
- Hg^{2+} as HgCl_2 can easily be scrubbed
- Hg^p can be removed in ESP
- Hg^0 can be physically adsorbed on activated carbon
- Catalyst Stores and Releases Mercury



Mercury in the Catalyst

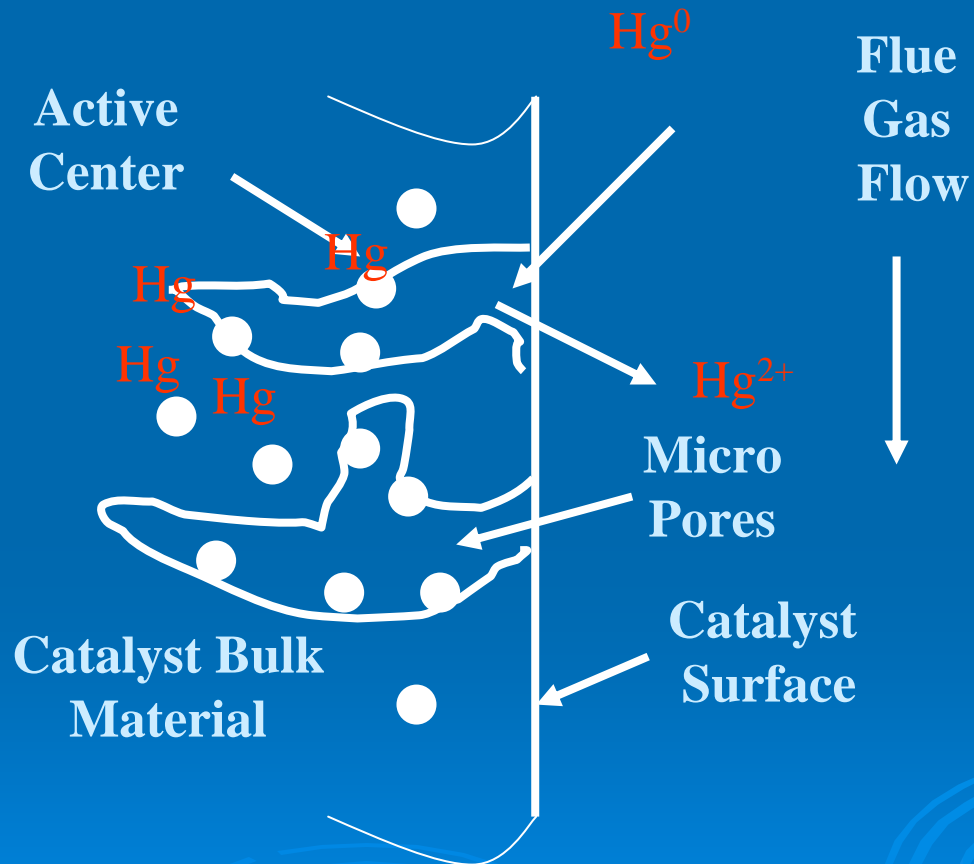

Chemical Reactions

- $\text{Hg}^0 + \text{Cl}_2 \longrightarrow \text{HgCl}_2$
- Combustion produces only HCl
- Deacon Reaction Catalyst Accelerated
 - $4 \text{HCl} + \text{O}_2 \longleftrightarrow 2 \text{Cl}_2 + 2 \text{H}_2\text{O}$
- Reactions take place on active centers of the catalyst
- Chlorine-Griffin Reaction
 - $\text{Cl}_2 + \text{SO}_2 + \text{H}_2\text{O} \longleftrightarrow 2 \text{HCl} + \text{SO}_3$



Reaction Mechanism

- SO_2 Oxidation Reaction Is A Chemical Reaction Controlled Mechanism
- Mercury Oxidation Is A Diffusion Controlled Mechanism
- Mercury Oxidation Reaction Depends On Activity of Catalyst



Mercury Desorption

Authors

Autoren

Professor Dr.-Ing. B. Vosteen
(ehemals BAYER AG)
Vosteen Consulting GmbH,
Köln/Deutschland.

Dipl.-Ing. J. Beyer
BAYER AG, Leverkusen/Deutschland.

Dipl.-Phys. Th.-G. Bonkhofer
BAYER AG, Leverkusen/Deutschland.

Dipl.-Ing. A. Pohontsch
(ehemaliger Diplomand bei BAYER AG).

Dipl.-Ing. Andrea Wieland
(ehemalige Diplomandin bei BAYER AG).

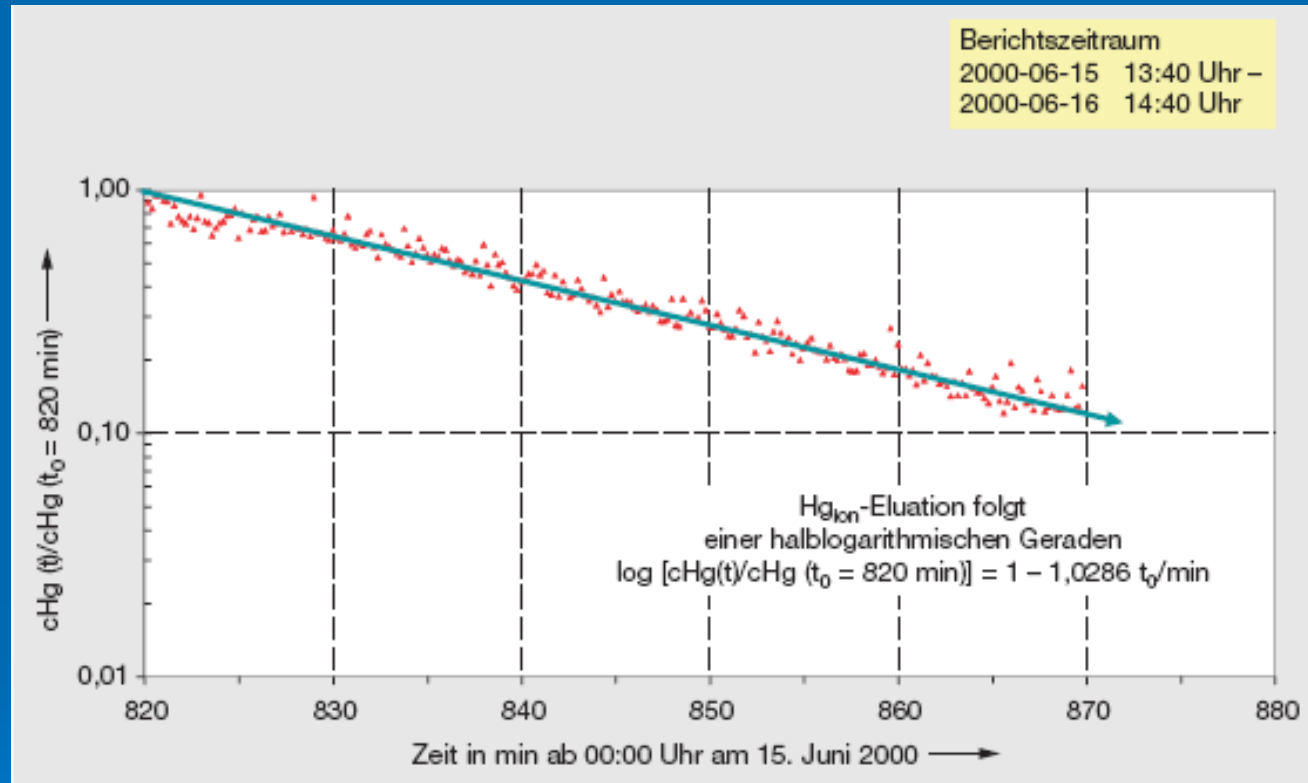

Source

VGB PowerTech 4/2003

Title

Mercury Retention by the Catalyst Bed of a Tail-end-SCR behind the Wet Flue Gas Cleaning of a Hazardous Waste Incineration Plant



Mercury Desorption

Authors

Autoren

Professor Dr.-Ing. B. Vosteen
(ehemals BAYER AG)
Vosteen Consulting GmbH,
Köln/Deutschland.

Dipl.-Ing. J. Beyer
BAYER AG, Leverkusen/Deutschland.

Dipl.-Phys. Th.-G. Bonkhofer
BAYER AG, Leverkusen/Deutschland.

Dipl.-Ing. A. Pohontsch
(ehemaliger Diplomand bei BAYER AG).

Dipl.-Ing. Andrea Wieland
(ehemalige Diplomandin bei BAYER AG).

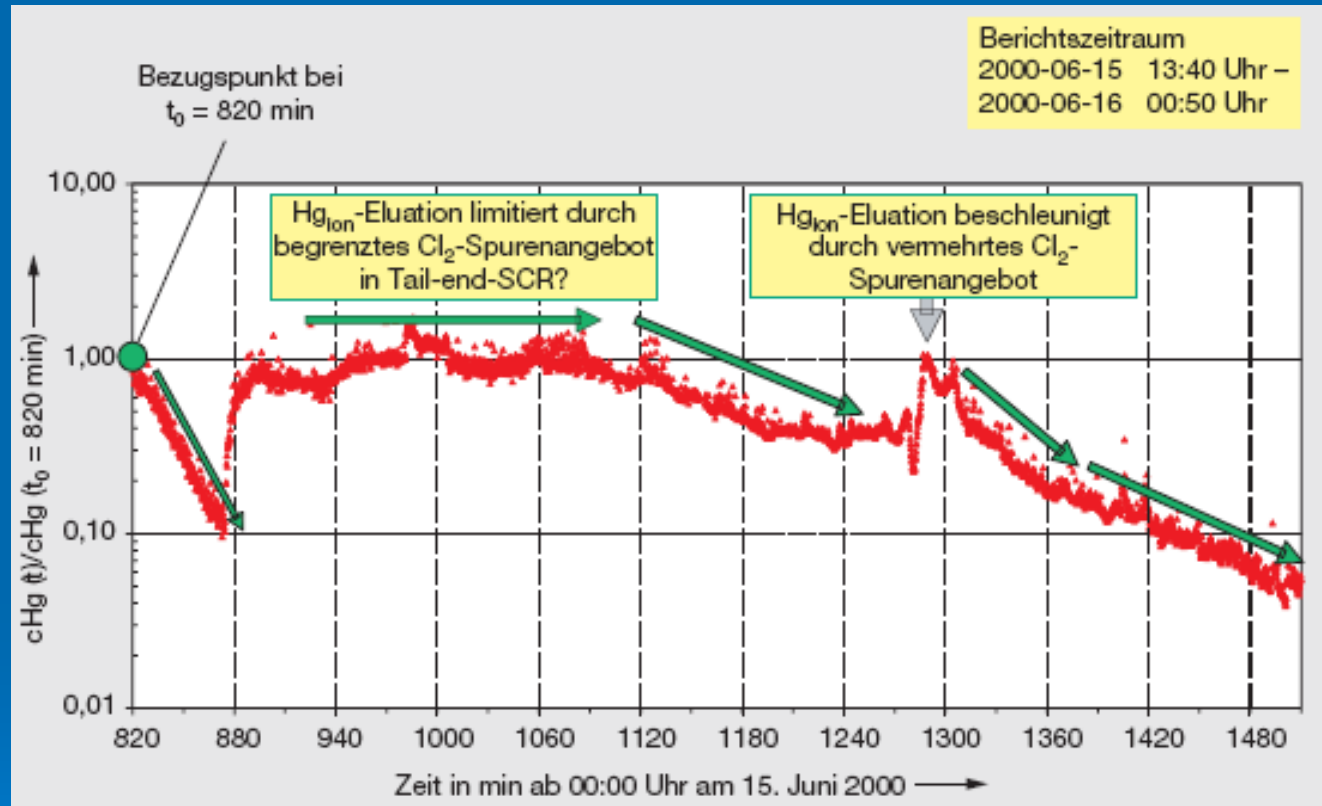

Source

VGB PowerTech 4/2003

Title

Mercury Retention by the Catalyst Bed of a Tail-end-SCR behind the Wet Flue Gas Cleaning of a Hazardous Waste Incineration Plant



Mercury on Particles

- Mercury can be adsorbed on carbon particles
 - Unburned Carbon
 - Activated Carbon Injection



Activated Carbon Injection And Flue Gas Conditioning

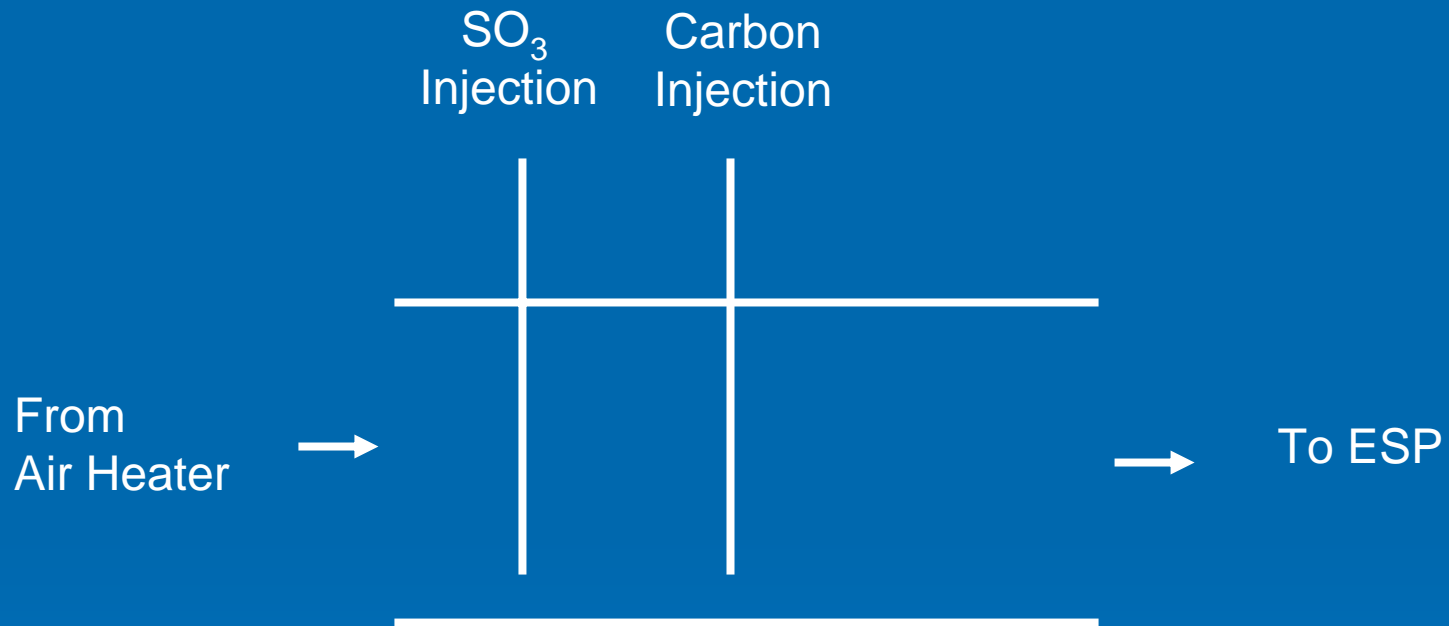

Activated Carbon Injection And Flue Gas Conditioning

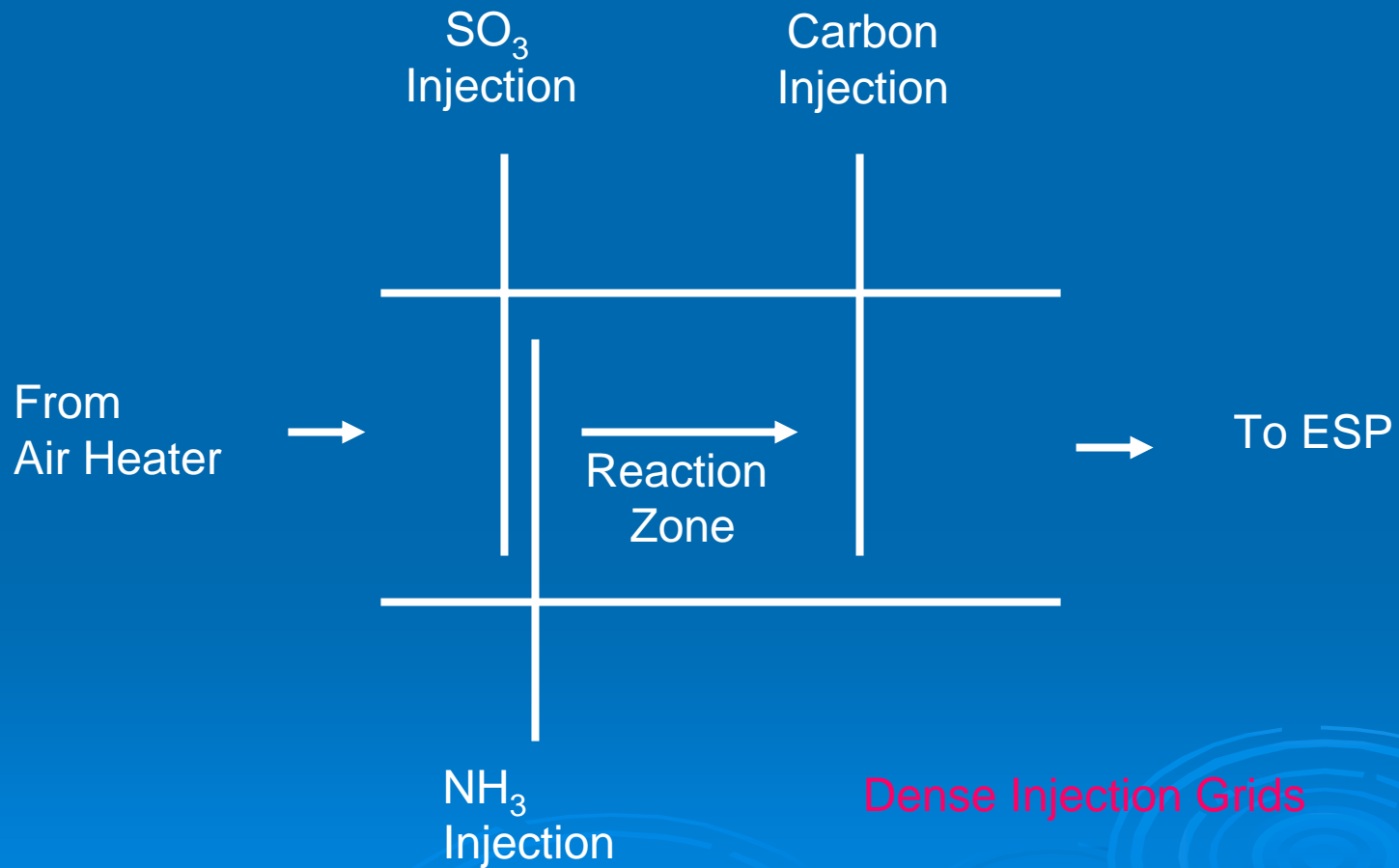

Summary

- Competing reactions on active cells
 - NO_x reduction
 - SO_2 Conversion
 - Mercury Oxidation
 - Chlorine Reactions
- Either Low Conversion Rate or Other Equipment



Conclusions

- Reducing the SO_3 Concentration becomes more and more important
- Catalyst with low SO_2/SO_3 conversion rate and capability to oxidize mercury and has enough capacity to last even if catalyst poisons are present is existing
- Chose the correct design conversion rate
- A layer more of catalyst may be the solution in many cases

