

WorleyParsons

Dampers, Expansion Joints, and ID Fans for Air Quality Control Retrofits

Jay Weist

25-July-05



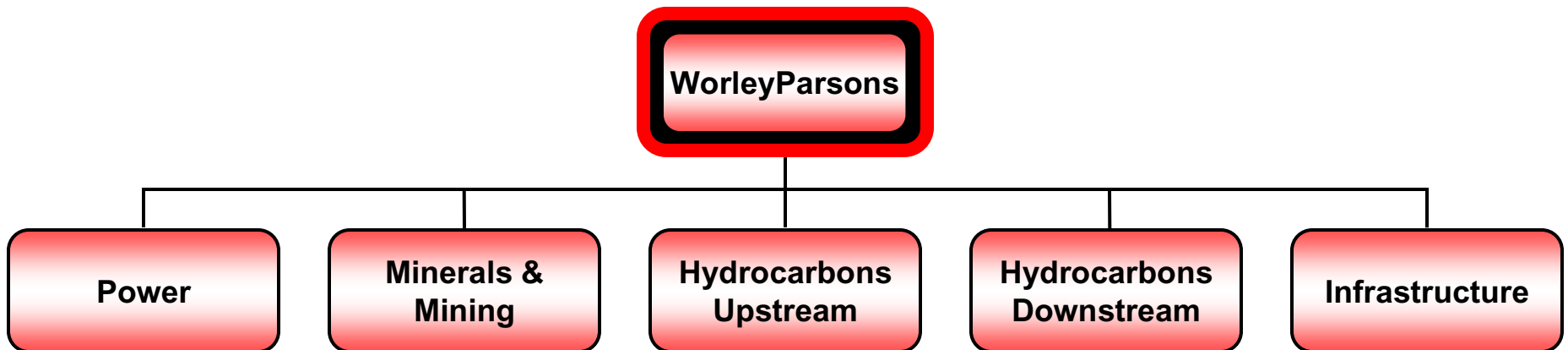



- ▶ Power
 - Coal-fired plants
 - Combustion turbine/combined cycle
 - Nuclear
 - Transmission distribution/substations
 - Air quality control
 - Gasification
 - Operations and maintenance
 - Owner's engineer
- ▶ Minerals & metals
 - Light metals
 - Base metals
 - Coal
 - Chemicals
 - Ferrous
- ▶ Upstream Hydrocarbons
 - Fixed offshore facilities
 - Onshore production facilities
 - Floating production systems
 - Subsea systems
 - Offshore and onshore pipelines
 - Processing plants
 - LNG/NGL/LPG
 - Terminals
- ▶ Downstream Hydrocarbons
 - Refining
 - Petrochemicals
 - Sulfur management
- ▶ Infrastructure
 - Transport
 - Industrial plants
 - Buildings
 - Defense
 - Environment



30 countries | 60 offices | 10,000 project services personnel



Coal – Over 35,000 MW



Gas Turbine – Over 33,000 MW



Nuclear – 11,100 MW



IGCC – 255 MW



- ▶ Dampers
 - Design criteria
 - SCR
 - Economizer by-pass
 - SCR by-pass
 - FGD
- ▶ Expansion joints
 - Design criteria
 - SCR
 - Post air heater
 - Absorber outlet
- ▶ Fans
 - Design criteria
 - Centrifugal
 - Axial



- ▶ Damper service
 - Ductwork (plenum) gas flow regulation/control
 - Equipment (absorber) gas flow control and/or isolation
 - Absorber by-pass control or isolation

- ▶ Damper types
 - Guillotine – for isolation (no pressure drop during operation), top entry preferred (acidic condensate and ash buildup in bottom of duct)
 - Louver – for flow control (quick acting, less than 30 seconds) and isolation (multi-louvers)
 - Parallel blade – better sealing, for isolation
 - Opposed blades – linear flow characteristics, for flow control



Typical Guillotine Damper

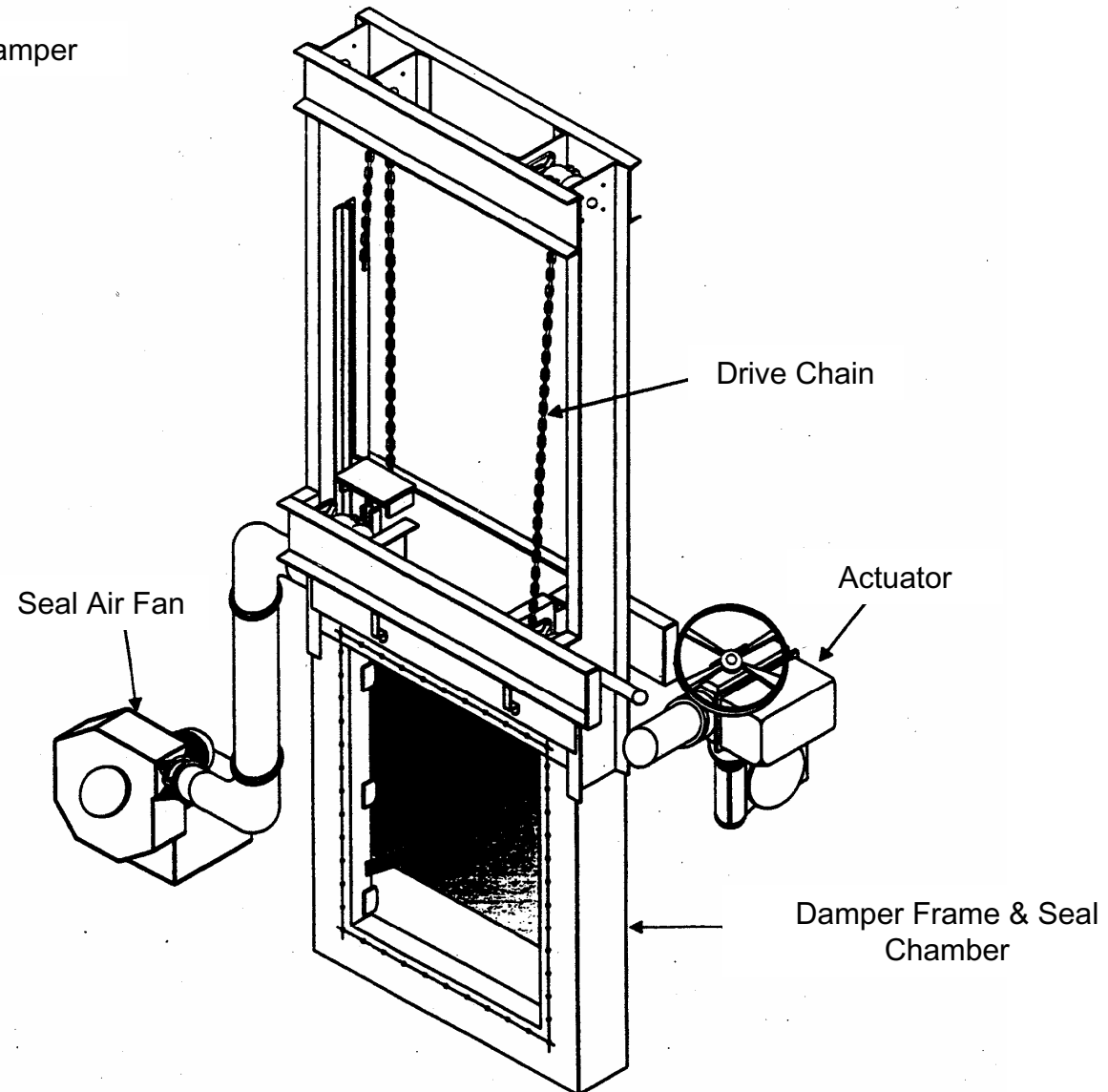



Typical Single Louver Damper

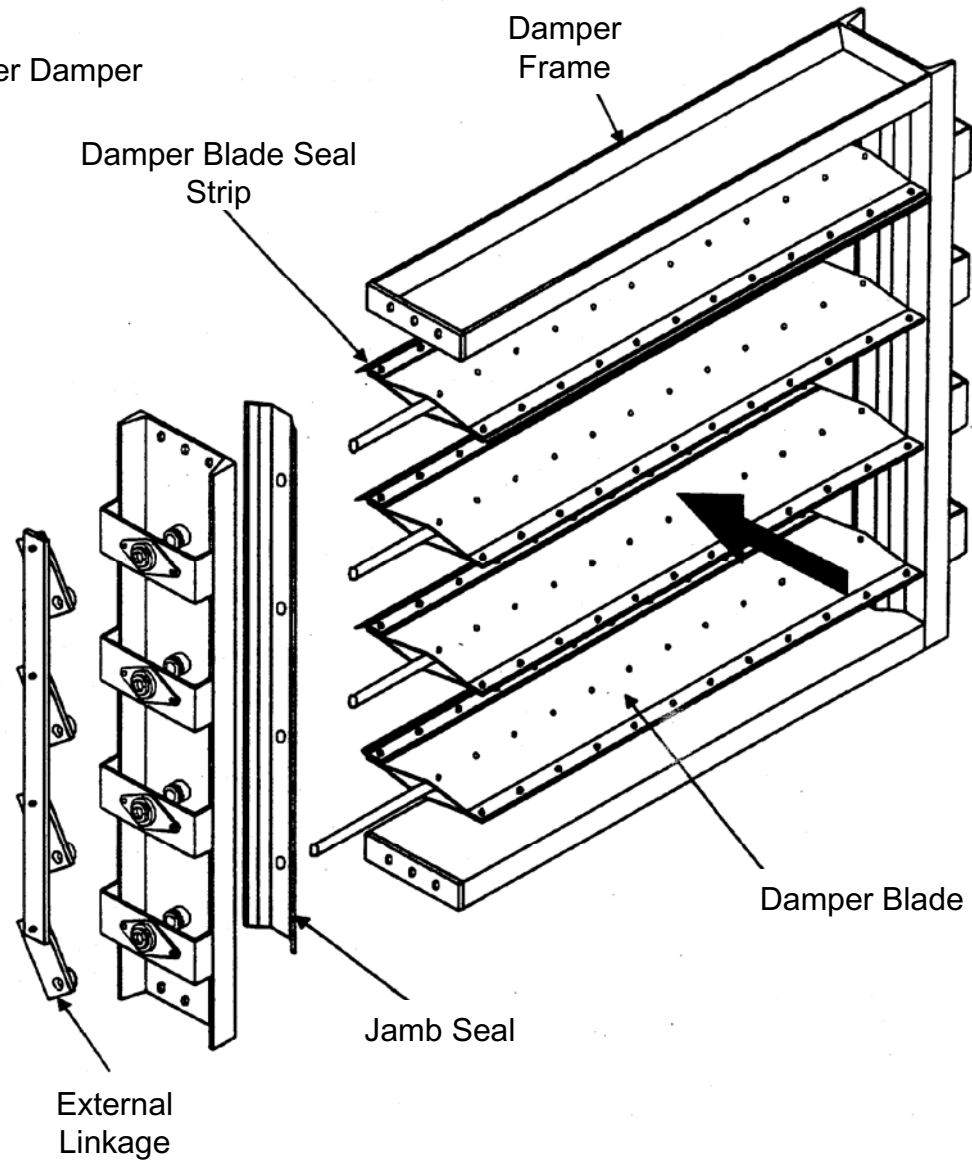



Typical Double Louver
Damper

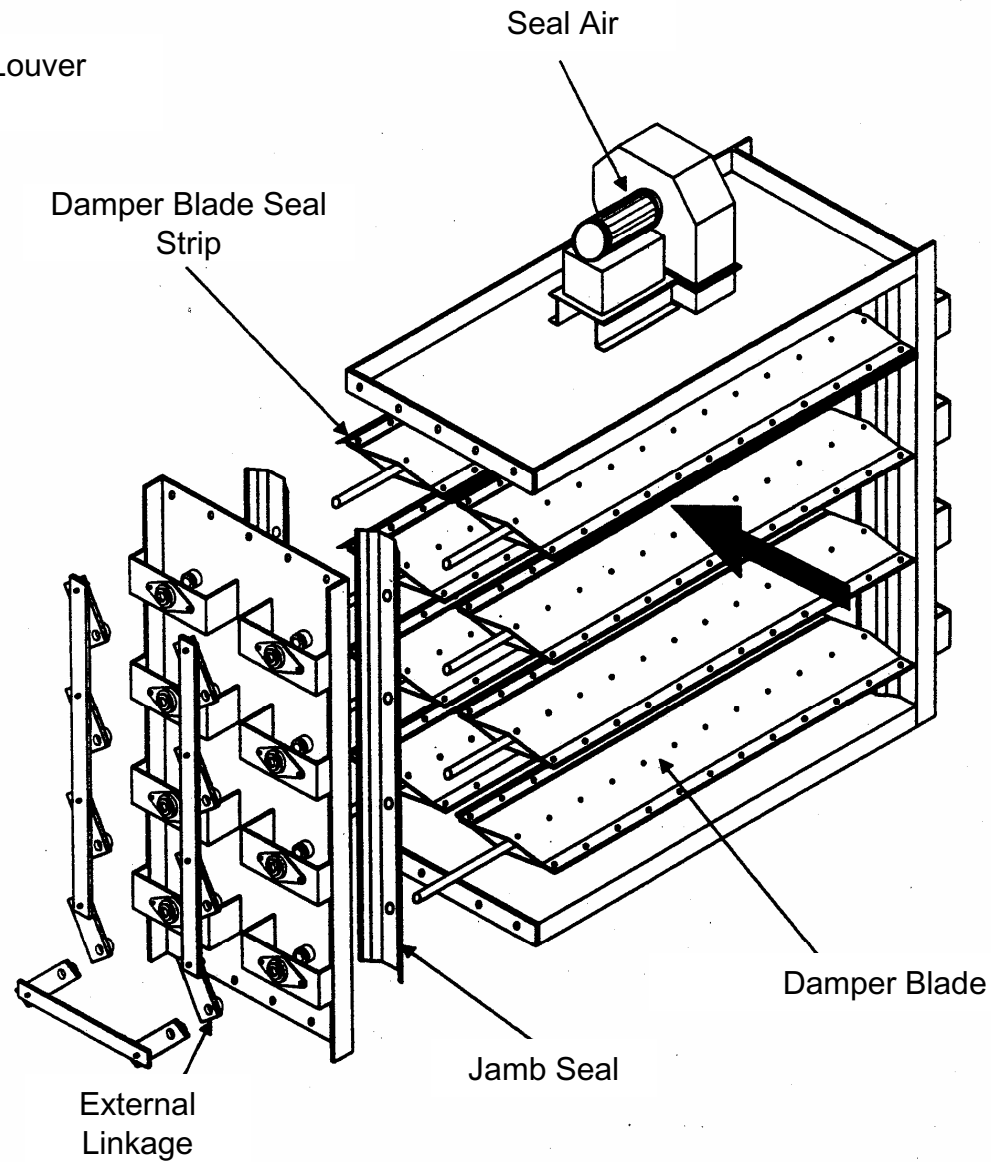

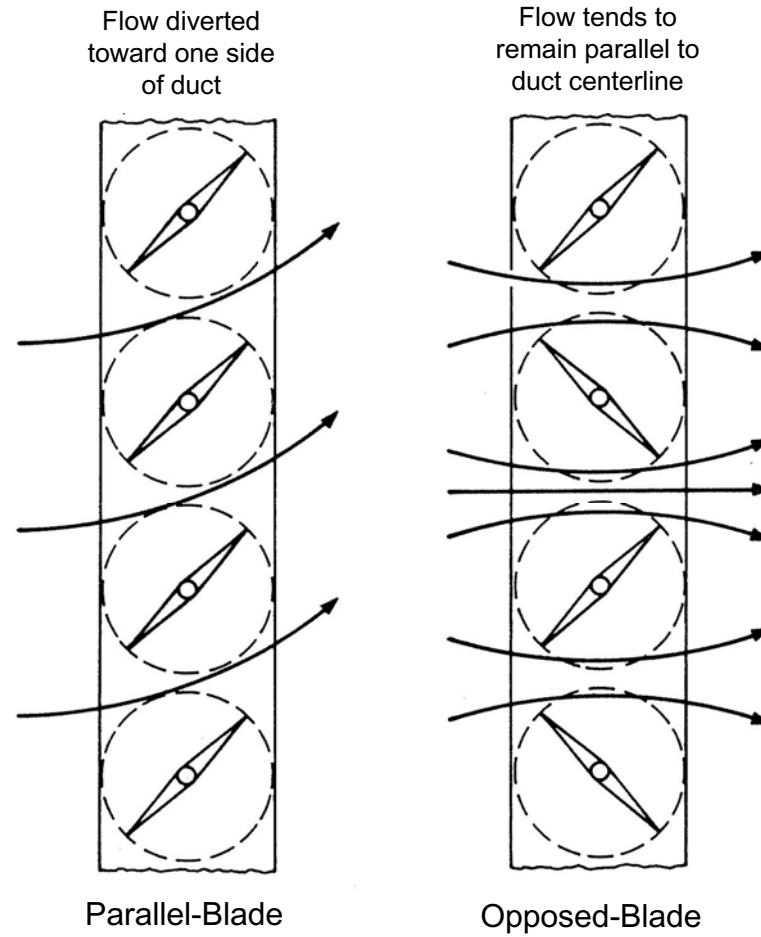

Blade Motion for Parallel-Blade and Opposed-Blade Louver Dampers



▶ Damper design

- Seals – blade-to-blade and frame seals for louvers and peripheral blades seals for guillotines (on both side of blade)
- Seal air system (for isolation dampers – “personnel safe”)
 - Required for zero leakage
 - Separate blower(s) on each damper or central blower → heated air may be appropriate
 - Guillotine – seal air in four-sided seal chamber
 - Louver – seal air between two louver dampers → more seal air
- Materials – seals need to be 300 series SS or high alloy, even for “dry,” 300°F dampers
- Structural – frames and blades designed as structural members → blade deflection criteria important
- Access – cranes or hoists to replace damper blades or drive motors



▶ **Styles**

- Single or double louver Damper
- BIPLANE
- Louver – opposed blade modulating
- Louver – parallel blade open/close
- Diverter – flap
- Isolation – guillotine



- ▶ Economizer by-pass
 - Modulating/Isolation
 - Modulating economizer by-pass
- ▶ SCR by-pass
 - Isolation/man-safe entry



- ▶ Type of service
 - Modulating
 - Shutoff/isolation
- ▶ Duct opening
- ▶ Blade depth
- ▶ Operating/design temperature
- ▶ Operating/design pressure
- ▶ Operator speed/stroke time
- ▶ Man-safe entry
- ▶ Pressure drop versus damper position
 - Predictable
 - Repeatable
- ▶ Flue gas constituents
- ▶ Ash analysis

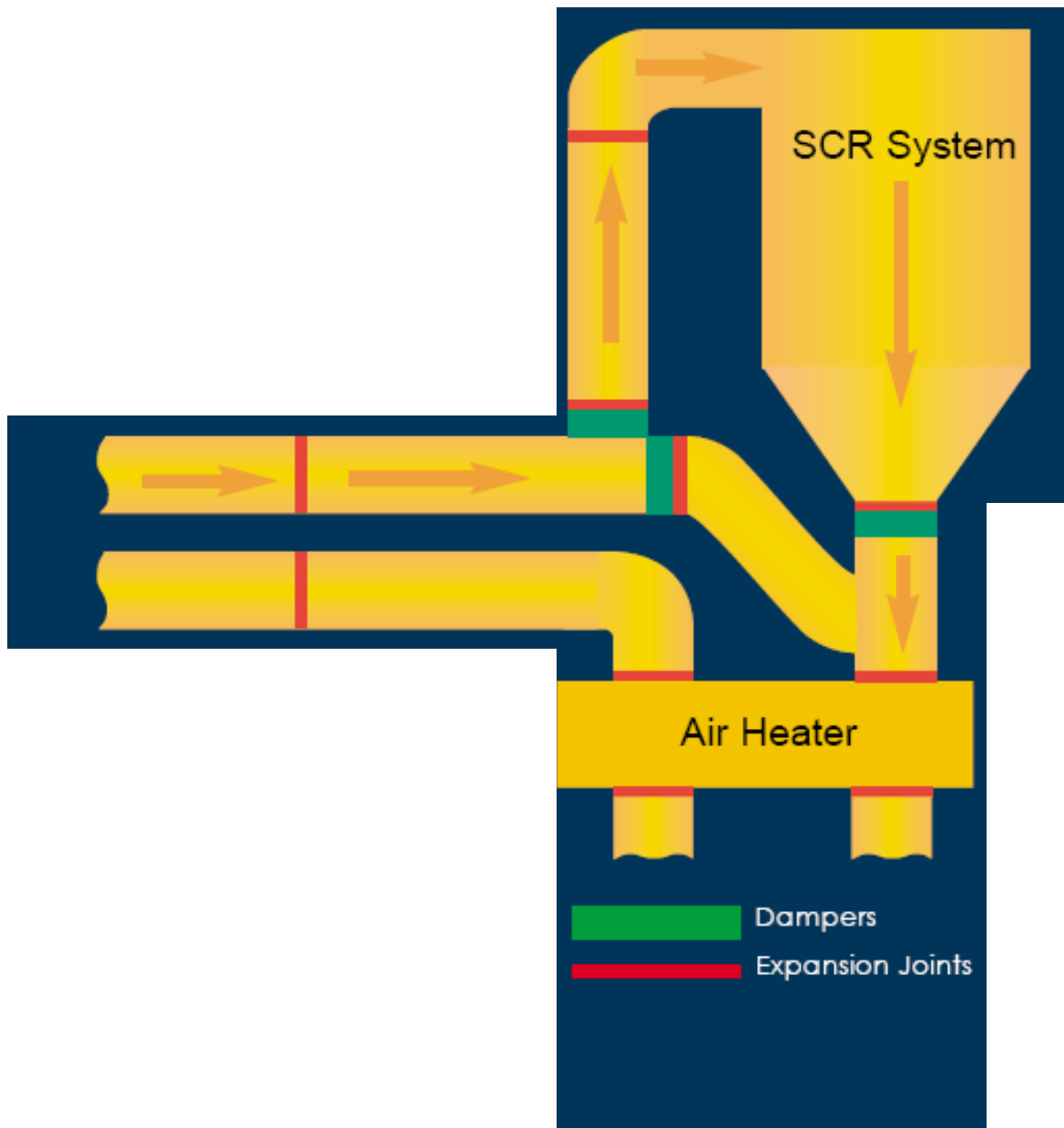

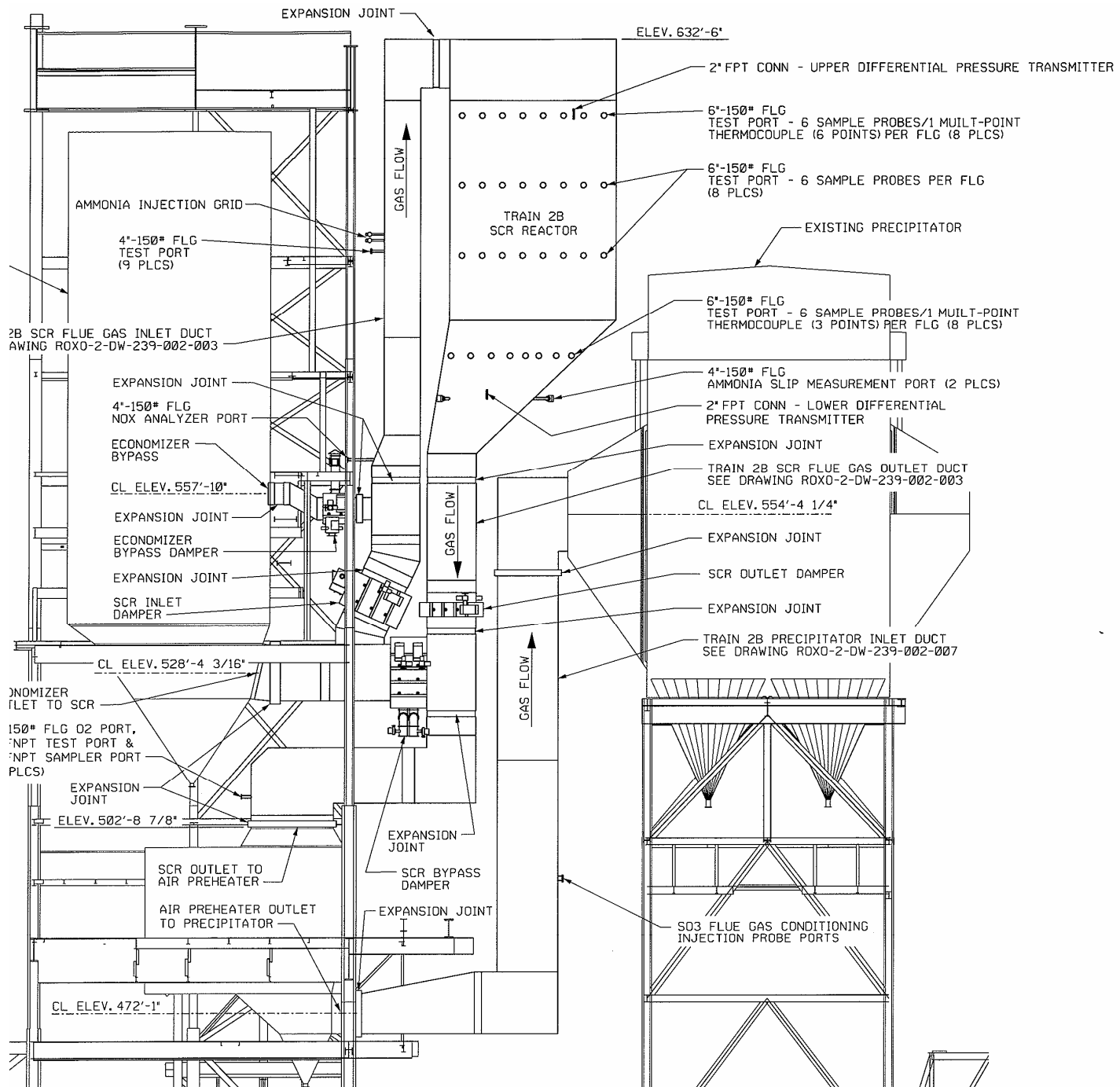

Zero leakage double louver for SCR service



Large duct span single louver for SCR service. Center support required due to large span at elevated temperatures



Double louver being shop tested for zero leakage capabilities



Hydraulically driven diverter for 600 MW coal-fired SCR



Flap type diverter for oil-fired SCR



Large ID fan isolation damper being tested in vertical position





- ▶ Isolation dampers/man-safe entry
 - Multiple boilers single absorber
 - Multiple flue gas paths single absorber
 - Multiple absorbers inlet
 - Multiple absorbers outlet
- ▶ Single train absorber – no dampers required
- ▶ Styles
 - Guillotine
 - Louver



- ▶ Isolation service/man-safe entry
- ▶ Duct opening
- ▶ Blade depth
- ▶ Operating/design temperature
- ▶ Operating/design pressure
- ▶ Materials of construction
 - Frame
 - Blades
 - Seals
- ▶ Flue gas constituents
- ▶ Ash analysis

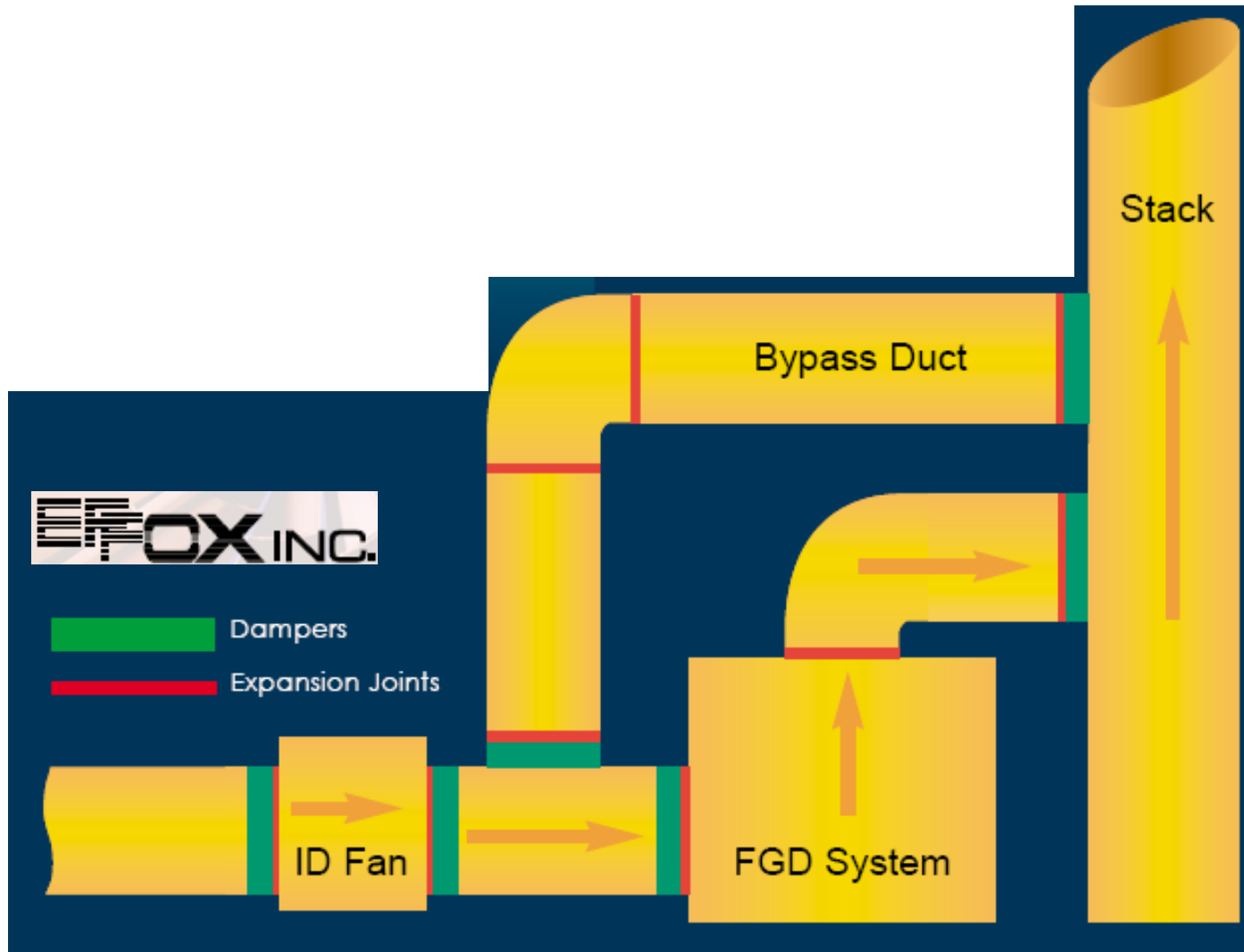



WorleyParsons

Fans, Flow Model, BOP Engineering,
Systems integration - Process tanks, piping,
BOP utilities – water, air, steam

Equipment Vendors

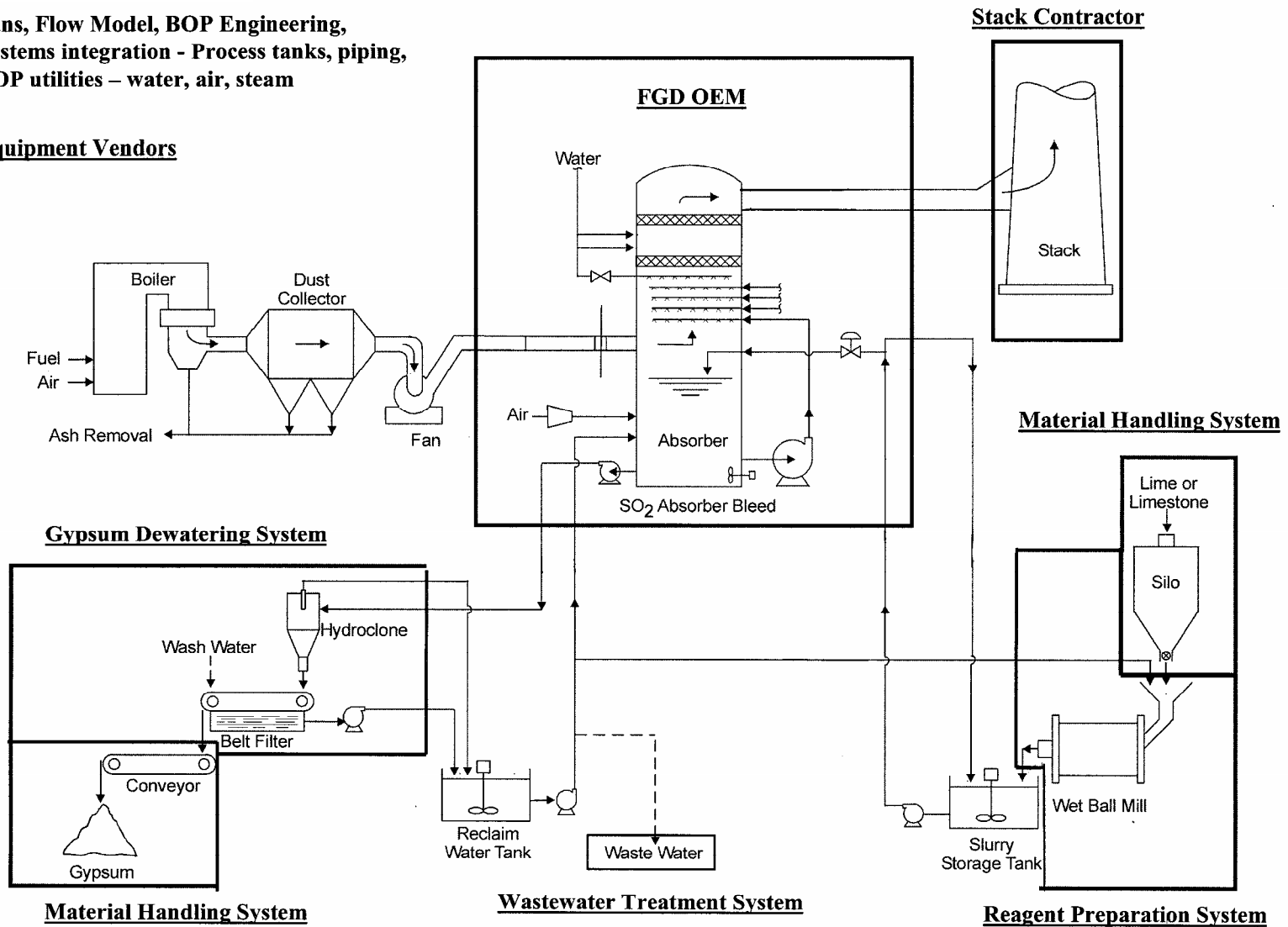



- ▶ Ambient – if seal air chamber is at least 3 in wg higher than duct pressure on both sides
- ▶ Pressurized – hot or cold air depending on acid gas potential
- ▶ Safety factor – 200% for volume at 3 in wg over system pressure

Seal air skid for zero leakage SCR double louver



Large zero leak guillotine damper with seal air fan mounted





- ▶ 700°F – 1100°F high temperature for SCR and economizer by-pass
- ▶ 250°F – 700°F mid-temperature for air heater to FGD absorber
- ▶ 100°F – 250°F wet expansion joints downstream of FGD absorber
- ▶ Life – 10, 15, or 20 years



- ▶ Flue gas flow
- ▶ Flue gas constituents
- ▶ SO₃ concentration
- ▶ Particulate loading
- ▶ Duct dimensions
- ▶ Corner radius – Six inches
- ▶ Mounting type
- ▶ Materials of construction
- ▶ Deflection
 - Axial (extended, compressed)
 - Lateral (long, short)
 - Breach
- ▶ Operating/design temperature
- ▶ Operating/design pressure



- ▶ Design
- ▶ Frame material – Chrome-Moly, SS, CS
- ▶ Erosion baffle – weld on or Z-frame
- ▶ Insulation – internal pillow or external
- ▶ Bolting – design temperature and bolt material depends on insulation
- ▶ Transient temperature, pressure, and duration



- ▶ Design
- ▶ Susceptible to acid attack
- ▶ Frame material – CS
- ▶ Erosion baffle – weld on or Z-frame
- ▶ Insulation – internal pillow or external
- ▶ VITON belt materials in a U-style frame do not require erosion baffles or insulation pillows
- ▶ Bolting – Zinc Plated CS (SS for acid resistance)
- ▶ Transient Temperature, pressure, and duration – typically 650°F for one hour for an air heater failure



- ▶ Design
- ▶ Exposed to supersaturated (WET) flue gas
- ▶ Liquids drains are required in EJ frame or duct (3" minimum, 4" or 6" is preferred)
- ▶ Frame material – FRP or AL6-XN
- ▶ Erosion baffle – none or AL6-XN – depending on frame style U or Belted
- ▶ Insulation – None
- ▶ Bolting – Zinc plated CS (SS for extra acid resistance)
- ▶ Transient temperature, pressure, and duration – typically 200°F - 220°F for 30 minutes for an absorber recycle pump failure with an emergency quench

Fabric expansion joint applications

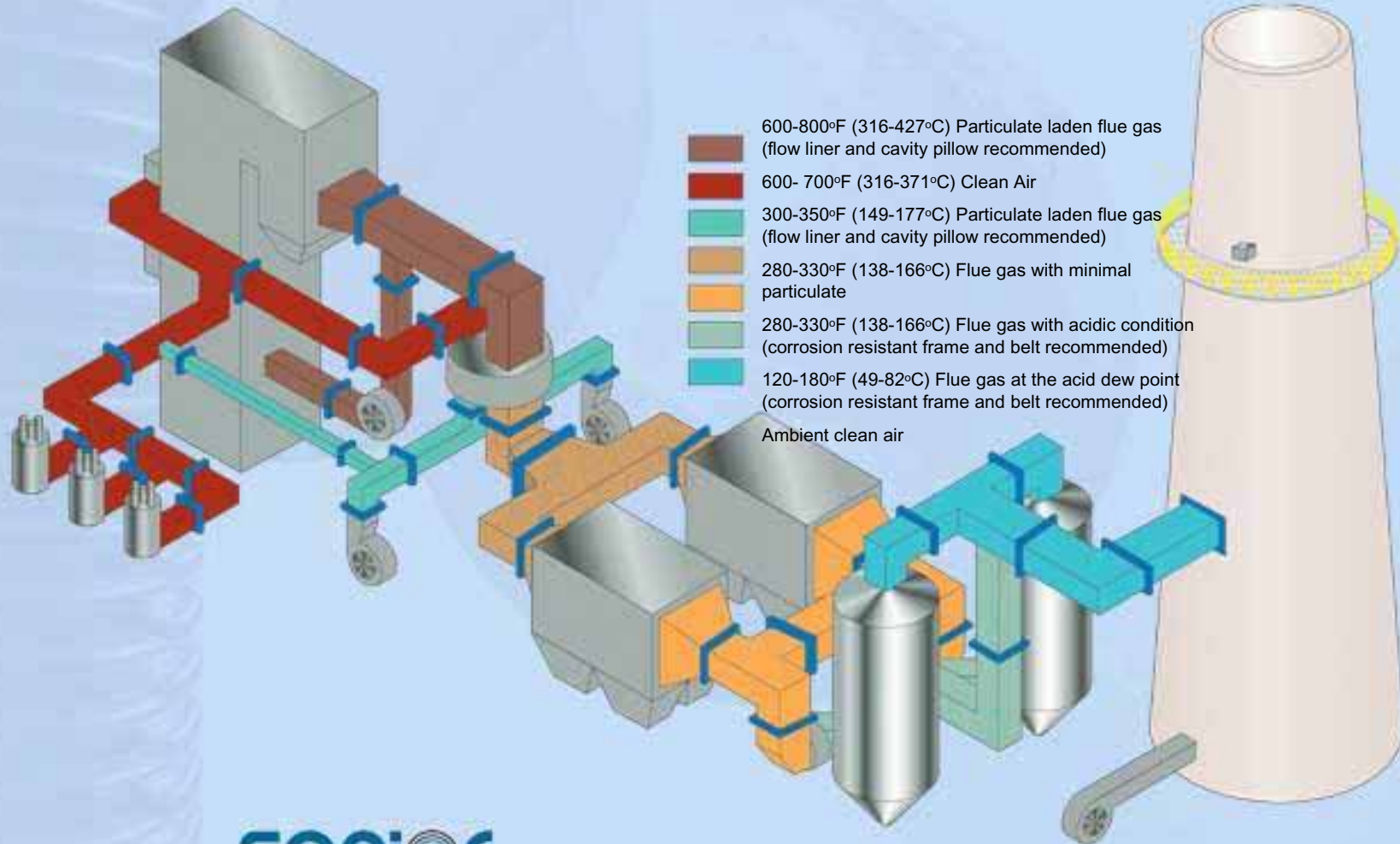



- ▶ Ability to absorb large motions in multiple planes
- ▶ Eliminates need for costly metal joints in toggle (universal)

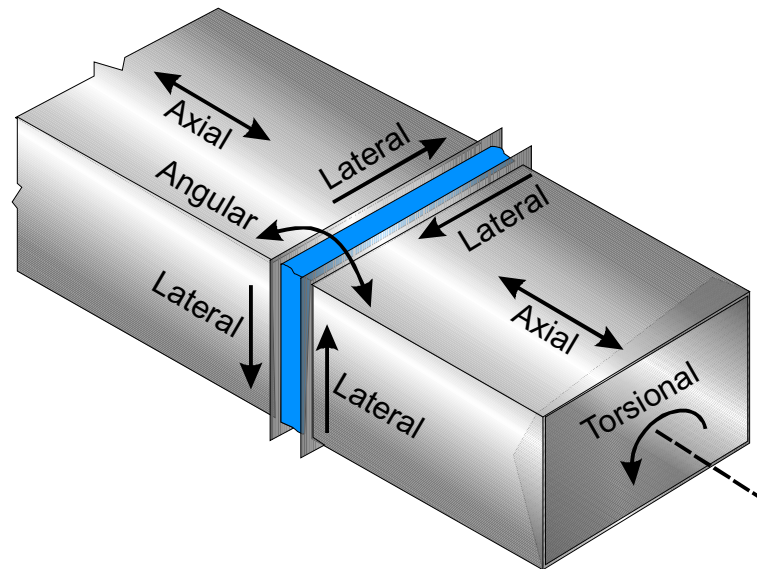

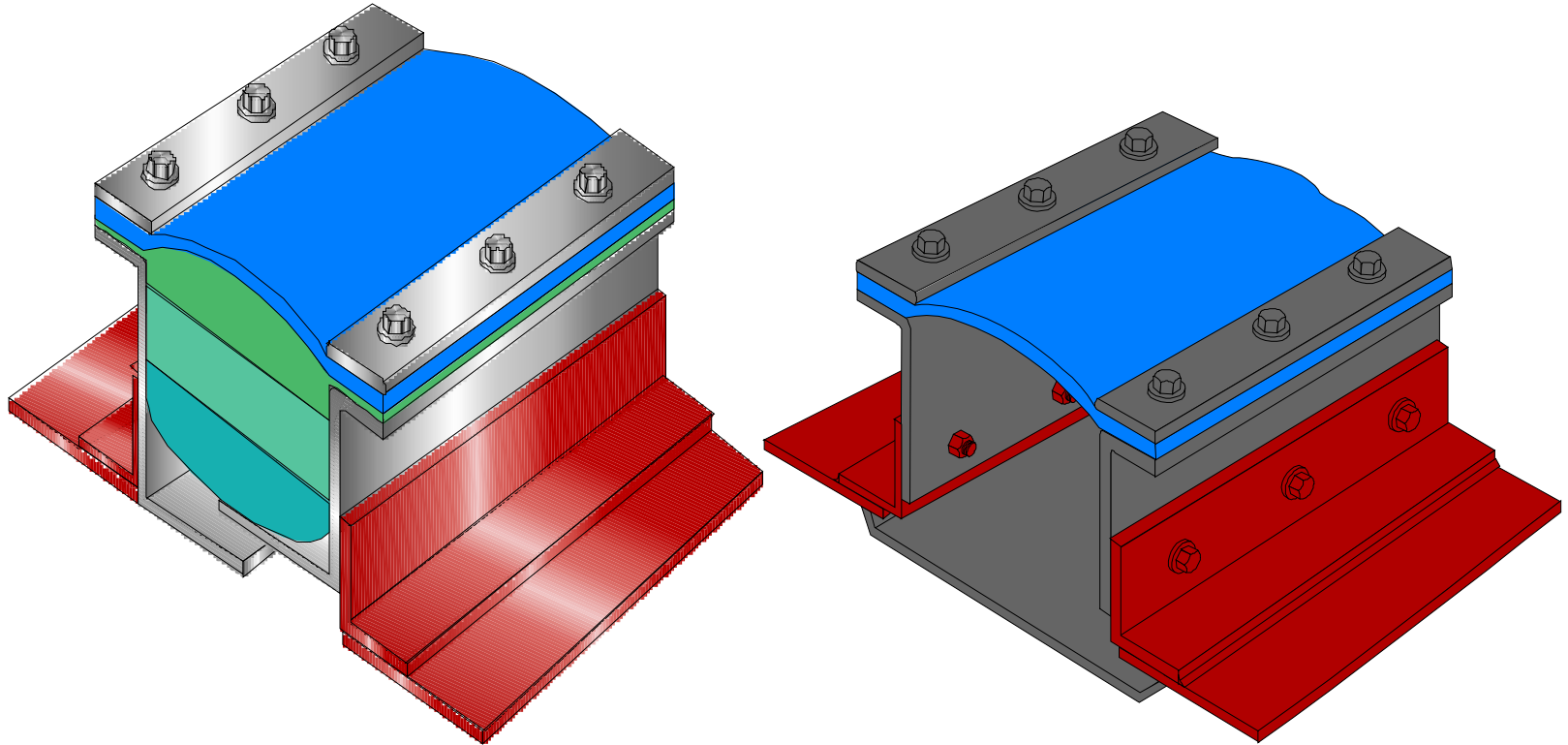



A Division of JM CLIPPER

Manufacturing Location:
 1413 S. University · Nacogdoches, TX 75961
 USA 800-233-3900 · Fax 936-564-8875

Charleston Sales Office:
 USA 800-800-7665
 Fax 843-554-6175



SUPERSPAN COLD SIDE

PRODUCT STANDARD FOR RM DYNEX SUPERSPAN EXPANSION JOINTS

STYLE		MATERIAL	SERVICE
MARK II FLEXTRA / F/G	Flange Geometry: RL-6769 Belt Geometry: RL-6782	<p>EPDM 1/4" NOM. REINFORCEMENT</p>	<p>Handles</p> <ol style="list-style-type: none"> 300°F (150°C) continuous 400°F (205°C) excursion pressure ± 5 psig (35kPa) <p>4. wet/dry flue gas service. Baffles not required. External insulation allowed.</p>
MARK II WIRE	Flange Geometry: RL-7398 Belt Geometry: RL-7423	<p>EPDM 1/8" 2-PLY KNIT WIRE</p>	<p>Handles</p> <ol style="list-style-type: none"> 300°F (150°C) continuous 400°F (205°C) excursion pressure ± 5 psig (35kPa) <p>4. wet/dry flue gas service. Baffles not required. External insulation allowed.</p>
MARK III FLEXTRA / F/G	Flange Geometry: RL-7422 Belt Geometry: RL-7421	<p>FLUOROELASTOMER COATED 1/4" NOM. REINFORCEMENT</p>	<p>Handles</p> <ol style="list-style-type: none"> 400°F (205°C) continuous 650°F (345°C) excursion pressure ± 5 psig (35kPa) <p>4. wet/dry flue gas service. Baffles not required. External insulation allowed.</p>
MARK III WIRE-F	Flange Geometry: RL-6809F Belt Geometry: RL-6810F	<p>FLUOROELASTOMER COATING FLEXTRA CLOTH 3/16" KNITTED 20cb3 WIRE MESH</p>	<p>Handles</p> <ol style="list-style-type: none"> 400°F (205°C) continuous 750°F (400°C) excursion pressure ± 5 psig (35kPa) <p>4. wet/dry flue gas service. Baffles not required. External insulation allowed.</p>
MARK III WIRE*	Flange Geometry: RL-6809 Belt Geometry: RL-6810	<p>FLUOROELASTOMER COATING 1/4" NOM. KNITTED WIRE MESH; CARP. 20</p>	<p>Handles</p> <ol style="list-style-type: none"> 400°F (205°C) continuous 750°F (400°C) excursion pressure ± 5 psig (35kPa) <p>4. wet/dry flue gas service. Baffles not required. External insulation allowed.</p>



A Division of JM CLIPPER







Manufacturing Location:
 1413 S. University · Nacogdoches, TX 75961
 USA 800-233-3900 · Fax 936-564-8875

Charleston Sales Office:
 USA 800-800-7665
 Fax 843-554-6175

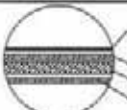

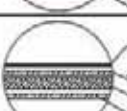
SUPERSPAN HOT SIDE

PRODUCT STANDARD FOR RM DYNE X SUPERSPAN EXPANSION JOINTS

STYLE		MATERIAL	SERVICE
MARK V SCR	Corrosive Service Belt Geometry: RL-8918	 <ul style="list-style-type: none"> BIAS CUT FLUOROPOLYMER/GLASS/PTFE RETAINER PLY 1" TEMPMAT INSULATION FIBERGLASS CLOTH FIBERGLASS CLOTH 	<p>Handles</p> <ol style="list-style-type: none"> 1000°F (540°C) continuous pressure ± 2 psig (15kPa) corrosive flue and chemical gas <p>Baffles required.</p> <p>External insulation not allowed. Insulation pillow required when</p> <ol style="list-style-type: none"> over 750°F (400°C) or pressure over 10" W.G. (2.5kPa)
MARK V FLEXTRA	Non-Corrosive Service Belt Geometry: RL-7427 Corrosive Service Belt Geometry: RL-7429	 <ul style="list-style-type: none"> FKM/FLEXTRA/FEP FLEXTRA FABRIC 1" GLASS MATT ALUMINIZED FLEXTRA INNER PLY 	<p>Handles</p> <ol style="list-style-type: none"> 1000°F (540°C) continuous pressure ± 2 psig (15kPa) corrosive flue and chemical gas <p>Baffles required.</p> <p>External insulation not allowed. Insulation pillow required when</p> <ol style="list-style-type: none"> over 750°F (400°C) or pressure over 10" W.G. (2.5kPa)
MARK V WIRE	Non-Corrosive Service Belt Geometry: RL-7132 Corrosive Service Belt Geometry: RL-7015	 <ul style="list-style-type: none"> FKM/WIRE FLEXTRA FABRIC 1/2" GLASS MATT TEFLON GLASS 1/2" GLASS MATT ALUMINIZED FLEXTRA FABRIC 	<p>Handles</p> <ol style="list-style-type: none"> 1000°F (540°C) continuous pressure ± 2 psig (15kPa) corrosive flue and chemical gas <p>Baffles required.</p> <p>External insulation not allowed. Insulation pillow required when</p> <ol style="list-style-type: none"> over 800°F or pressure over 10" W.G. (2.5kPa)
MARK V FLUOROPOLYMER	Corrosive Service Belt Geometry: C-800T	 <ul style="list-style-type: none"> PTFE/GLASS COVER RETAINER PLY TEFLON HEAT TREATED FABRIC 1/2" INSULATION HEAT TREATED FABRIC 	<p>Handles</p> <ol style="list-style-type: none"> 1000°F (540°C) continuous pressure ± 2 psig (15kPa) corrosive flue and chemical gas <p>Baffles required.</p> <p>External insulation not allowed. Insulation pillow required when</p> <ol style="list-style-type: none"> over 750°F (400°C) or pressure over 10" W.G. (2.5kPa)
MARK V MODIFIED	Non-Corrosive Service Belt Geometry: RL-7431 Corrosive Service Belt Geometry: RL-7433	 <ul style="list-style-type: none"> EPDM/FLEXTRA/FEP FLEXTRA FABRIC 1/2" GLASS MATT FLEXTRA FABRIC 	<ol style="list-style-type: none"> 500°F (260°C) continuous 750°F (400°C) continuous pressure ± 2 psig (15kPa) flue and chemical gas. Gas required. External insulation not allowed.
MARK V MODIFIED	Non-Corrosive Service Belt Geometry: RL-7124 Corrosive Service Belt Geometry: RL-7027	 <ul style="list-style-type: none"> FKM/WIRE FLEXTRA FABRIC 1/2" GLASS MATT PTFE/GLASS INNER PLY 	<p>Handles</p> <ol style="list-style-type: none"> 550°F 750°F (400°C) continuous pressure ± 2 psig (15kPa) flue and chemical gas. Gas required. External insulation not allowed.
MARK V MODIFIED FLUOROPOLYMER	Corrosive Service Belt Geometry: C-500T	 <ul style="list-style-type: none"> PTFE/GLASS COVER 1/2" INSULATION PTFE HEAT TREATED FABRIC 	<p>Handles</p> <ol style="list-style-type: none"> 500°F (260°C) continuous 750°F (400°C) continuous pressure ± 2 psig (15kPa) flue and chemical gas. Gas required. External insulation not allowed.
INSULATION PILLOW	Glass Fabric Casing: RL-7325 Ceramic Fabric Casing: RL-7465	 <ul style="list-style-type: none"> COATED GLASS FABRIC OR COATED CERAMIC FABRIC (WIRE INSERTED) GLASS OR CERAMIC INSULATION THICKNESS: 4" (100mm) 	<p>Use with Mark V expansion joint when temperatures are in excess of 750°F (400°C) or there is a problem of fly ash loading.</p>

Frame Styles



- ▶ VARIOUS STYLES
- ▶ MATERIALS
- ▶ WELD-IN / BOLT-IN
- ▶ WITH OR WITHOUT FLANGES
- ▶ RADIUS CORNERS / STD SIZES
SETBACK / HOLE SPACING

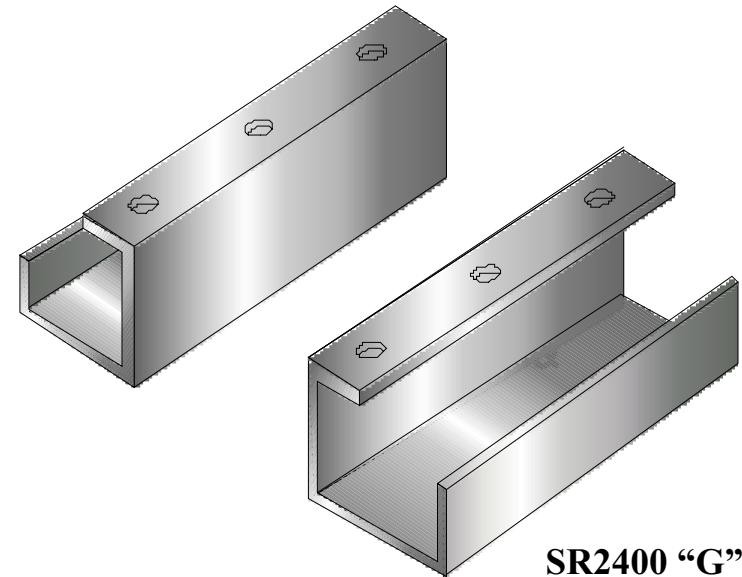

**SR2400 "G"
FRAME**

U1000 SERIES	2400 SERIES	2500 SERIES	2600 SERIES	2700 SERIES	2750 SERIES	2800 SERIES	2900 SERIES



Manufacturing Location:
 1413 S. University · Nacogdoches, TX 75961
 USA 800-233-3900 · Fax 936-564-8875

Charleston Sales Office:
 USA 800-800-7665
 Fax 843-554-6175



SUPERSPAN

MOVEMENT DESIGN STANDARD

RM DYNE X SUPERSPAN EXPANSION JOINTS

MFG F/F	BREACH OPENING	AXIAL COMPRESSION		AXIAL EXTENSION		LATERAL RESULTANT	
MARK II, III WIRE* MARK III WIRE F*		OPERATING	EXCURSION	OPERATING	EXCURSION	OPERATING	EXCURSION
***(ELASTOMERIC JOINTS)							
6" (152mm)	5½" (140mm)	1½" (38mm)	2¼" (57mm)	½" (13mm)	1½" (38mm)	2½" (57mm)	
9" (230mm)	8½" (215mm)	2½" (70mm)	4¼" (120mm)	¾" (19mm)	2½" (70mm)	4¼" (110mm)	
12" (305mm)	11" (280mm)	3½" (90mm)	6¼" (160mm)	1" (25mm)	3½" (90mm)	5¼" (135mm)	
16" (405mm)	15" (380mm)	5" (130mm)	8¼" (220mm)	1" (25mm)	5" (130mm)	7¼" (190mm)	
**MARK V MODIFIED (COMPOSITE JOINTS)							
6" (150mm)	5½" (140mm)	1" (25mm)		½" (13mm)	1" (25mm)		
9" (230mm)	8½" (215mm)	2½" (65mm)		½" (13mm)	2½" (65mm)		
12" (305mm)	11" (280mm)	3¼" (85mm)		1" (25mm)	3¼" (85mm)		
16" (405mm)	15" (380mm)	4½" (115mm)		1" (25mm)	4½" (115mm)		
**MARK V (COMPOSITE JOINTS)							
6" (150mm)	5½" (140mm)	1" (25mm)		½" (13mm)	1" (25mm)		
9" (230mm)	8½" (215mm)	2" (50mm)		¾" (19mm)	2" (50mm)		
12" (305mm)	11" (280mm)	3" (75mm)		1" (25mm)	3" (75mm)		
16" (405mm)	15" (380mm)	4" (100mm)		1" (25mm)	4" (100mm)		

*Patent 4,403,796 **Recommended in Belt Geometry ***Recommended in Flange Geometry

SECTION VIEW OF EXPANSION JOINTS

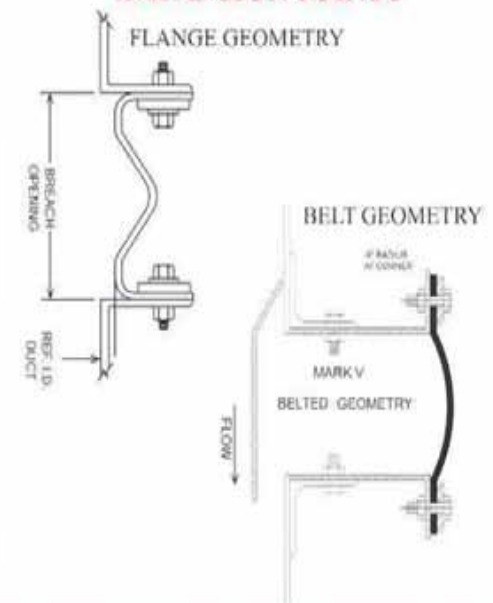

DESIGN NOTES:

- 6" (150MM), 9" (230MM), 12" (305MM), 16" (405MM) are standard manufactured expansion joint F/F. RM DYNE X offers other sizes for special conditions, or on request.
- Extension may be increased by decreasing breach opening (pre-compression). However, compression will be reduced equal to extension increase.
- In general, resultant lateral should not exceed the compression. If necessary, this may be achieved by pre-compression.
- Lateral movements exceeding 5" (125MM) should be pre-offset one half the required movement. Review offset requirements with RM DYNE X.
- Breach opening tolerances: Axial: ¼" (6mm) Extension, ½" (13mm) Compression; Lateral: = ½" (13mm)

AXIAL EXPANSION CALCULATIONS:

DUCT MATERIAL:
 CARBON STEEL
 EXPANSION (in.) = $8.0 \times 10^{-5} \times l \times \Delta T$
 STAINLESS STEEL
 EXPANSION (in.) = $1.2 \times 10^{-4} \times l \times \Delta T$
 FIBERGLASS
 EXPANSION (in.) = $1.8 \times 10^{-4} \times l \times \Delta T$
 EXPANSION (cm.) = $1.2 \times 10^{-3} \times m \times \Delta c$
 EXPANSION (cm.) = $1.65 \times 10^{-3} \times m \times \Delta c$
 EXPANSION (cm.) = $2.7 \times 10^{-3} \times m \times \Delta c$

l = linear feet of duct from anchor point
 ΔT = service temperature less ambient temperature in °F
 m = linear meters of duct from anchor point
 Δc = service temperature less ambient temperature in °C

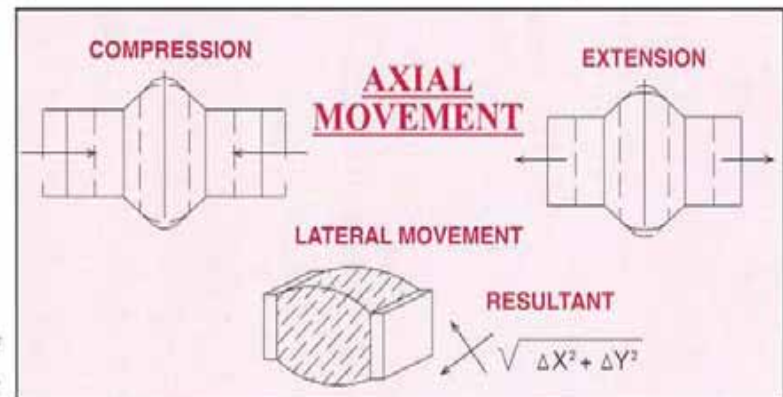

SR2400 “G-Frame”



- ▶ Highest cost, lower installed cost
- ▶ Easiest installation
- ▶ Floating mating flange

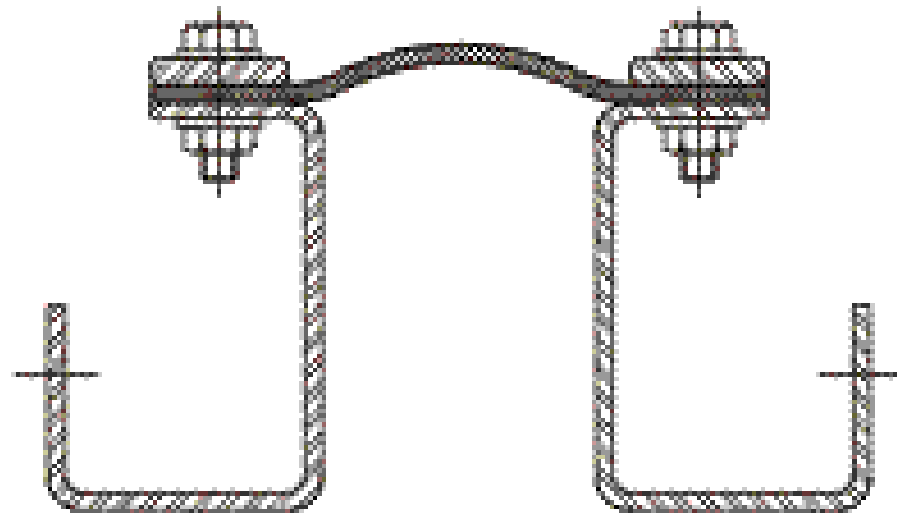

SR2700 or 2750 “Z-Frame”



- ▶ Lowest installed cost if flow liners are required
- ▶ Floating mating flange
- ▶ May require pre-compression

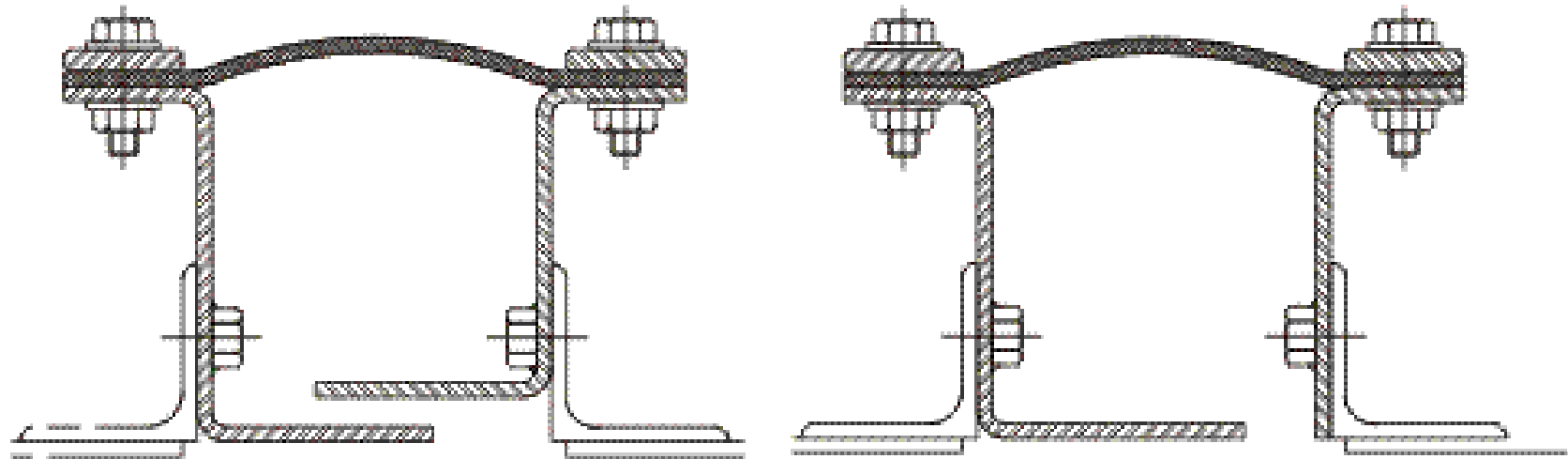

SR2800 “Angle Frame”



- ▶ Lowest installed cost if flow liner is not required
- ▶ Floating mating flange
- ▶ May require pre-compression

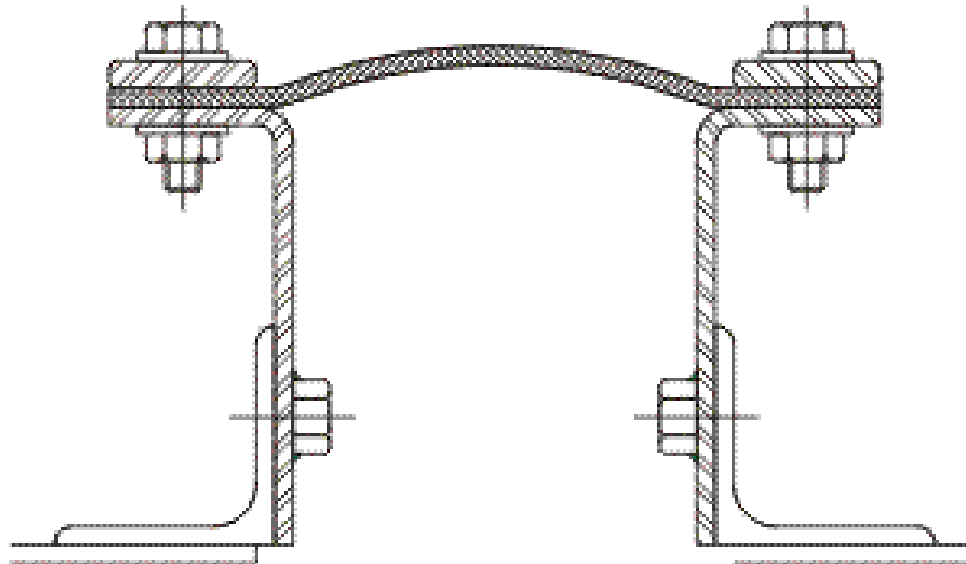

U1000

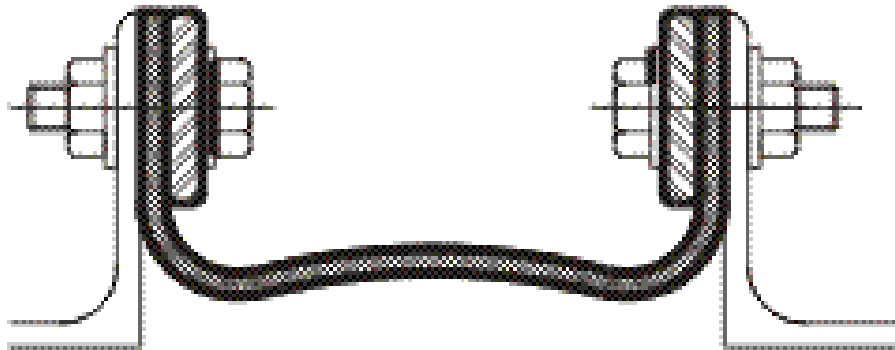

Common

- ▶ Smaller variance for floating flanges
- ▶ Fabricated corners
- ▶ Less movement capability
- ▶ Lower steel frame cost
- ▶ Higher belt cost

Rubber

- ▶ Maximum temperature 400 deg. F
- ▶ Abrasion resistant - Yes
- ▶ Flutter resistant - Yes

Teflon/Darlyn

- ▶ 600-900 deg. F depending on belt type and required movement
- ▶ No, unless a liner is used
- ▶ Yes/No, depends on belt style

Drains

Belt Drain

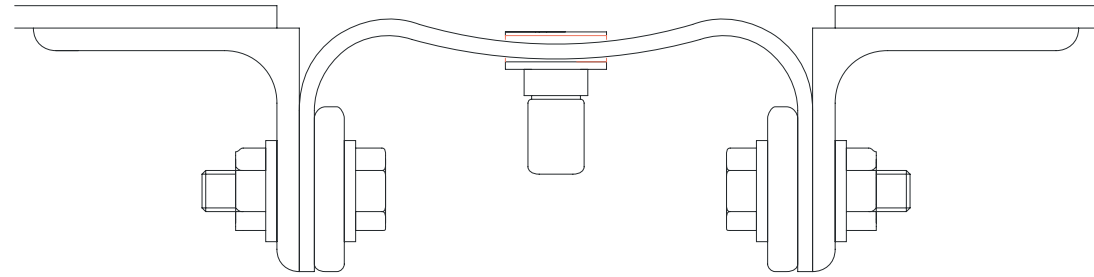

Frame Drain

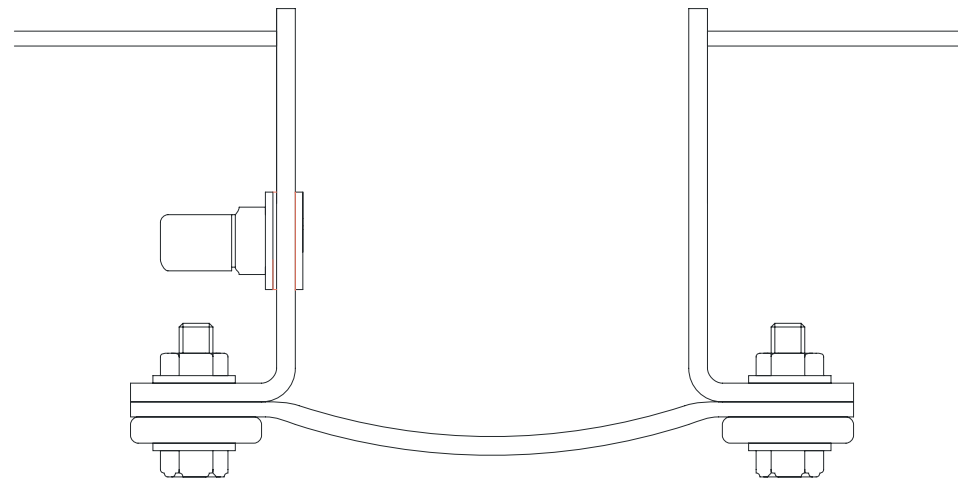

Belt Leakage Anatomy



Typical leakage points

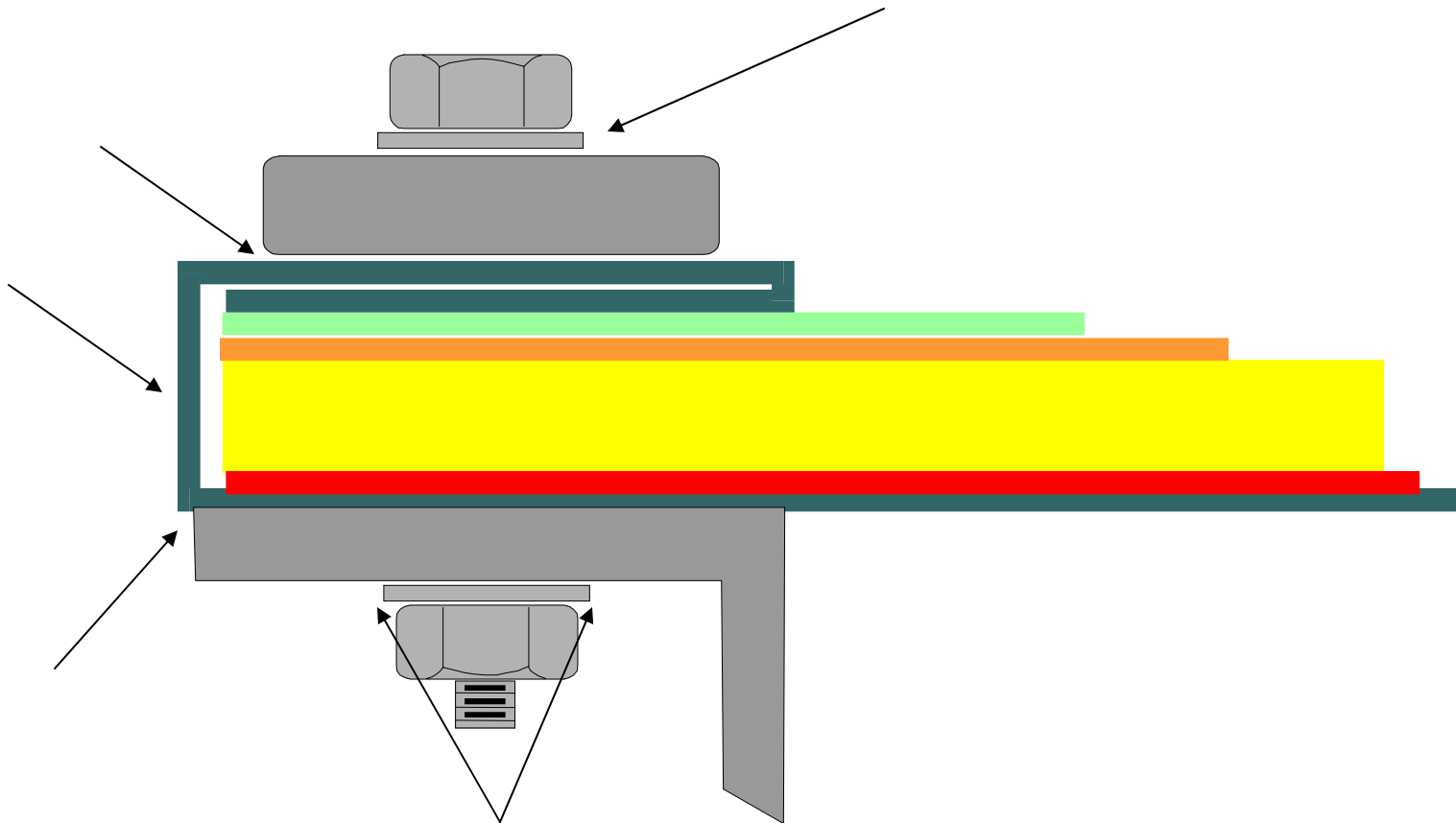



- ▶ Type
 - Centrifugal – conventional boiler ID fans
 - Axial – used in Europe after absorber due to wider use of axial fans in power plants for ID fan service (Note: Europe uses reheat to further reduce moisture after mist eliminator)
- ▶ Location
 - Pressurized absorber – hot, dry, clean flue gas (dry fans)
 - Negative pressure absorber – water saturated flue gas (“wet” fans)
- ▶ Service
 - FGD booster fan – controls more complex
 - Combined boiler ID / FGD booster fan – new fan or modified existing ID fan



▶ Design

- Dry (positive pressure)
 - Higher temperature → higher gas flowrate (volume)
 - Larger fan and motor than wet fans
- Wet (negative pressure)
 - Saturation temperature (~125°F) → lower gas flowrate (volume)
 - Negative pressure structure design more difficult
 - Smaller fan and motor than dry fans
 - In-leakage increases gas flow
 - Mist eliminators operation critical – to avoid fan deposits
 - Wash system to remove deposits from rotor → reduce corrosion and rotor imbalance due to solids buildup
 - Poor reliability (USA experience)



▶ **Materials**

- Pressurized absorber – conventional fan material for ~300°F flue gas (carbon steel)
- Negative pressure absorber – water-saturated flue gas (~125°F), with very acidic and high chloride conditions
 - Reheat – theoretically dry, but upset conditions should dictate
 - No reheat
 - Nickel alloys for rotors and blades (stainless not recommended due to chlorides), rubber lining has been used in USA
 - Linings and coatings can be used for housing → poor experience

▶ **Structural**

- Increased negative pressure excursions/transient for existing plants – boiler implosion



-
- ▶ A 600 MW SCR/FGD retrofit requires two 10,000+ HP centrifugal fans



- ▶ Cold start
- ▶ Load variation
- ▶ Dampers and VIVs 2 to 4 : 1
- ▶ Hydraulic drives 4 to 10 : 1
- ▶ Variable frequency drive 10+ : 1



- ▶ Inlet dampers
- ▶ Variable inlet vanes
- ▶ Variable hydraulic coupling
- ▶ Variable frequency drives
- ▶ Lowest initial cost/highest operating cost
- ▶ Highest initial cost/lowest operating cost



- ▶ (8) 145.25 in. diameter airfoil bladed ID fans
- ▶ Voith vorecon geared fluid drive
- ▶ 8000 HP, 900 RPM motors
- ▶ Inlet and discharge dampers with actuators
- ▶ Overspeed and impact tests of rotors
- ▶ Radiography of CPL and flange welds
- ▶ Shipped in summer of 2001



POWER SAVING WITH VOITH VARIABLE SPEED TURBO COUPLING

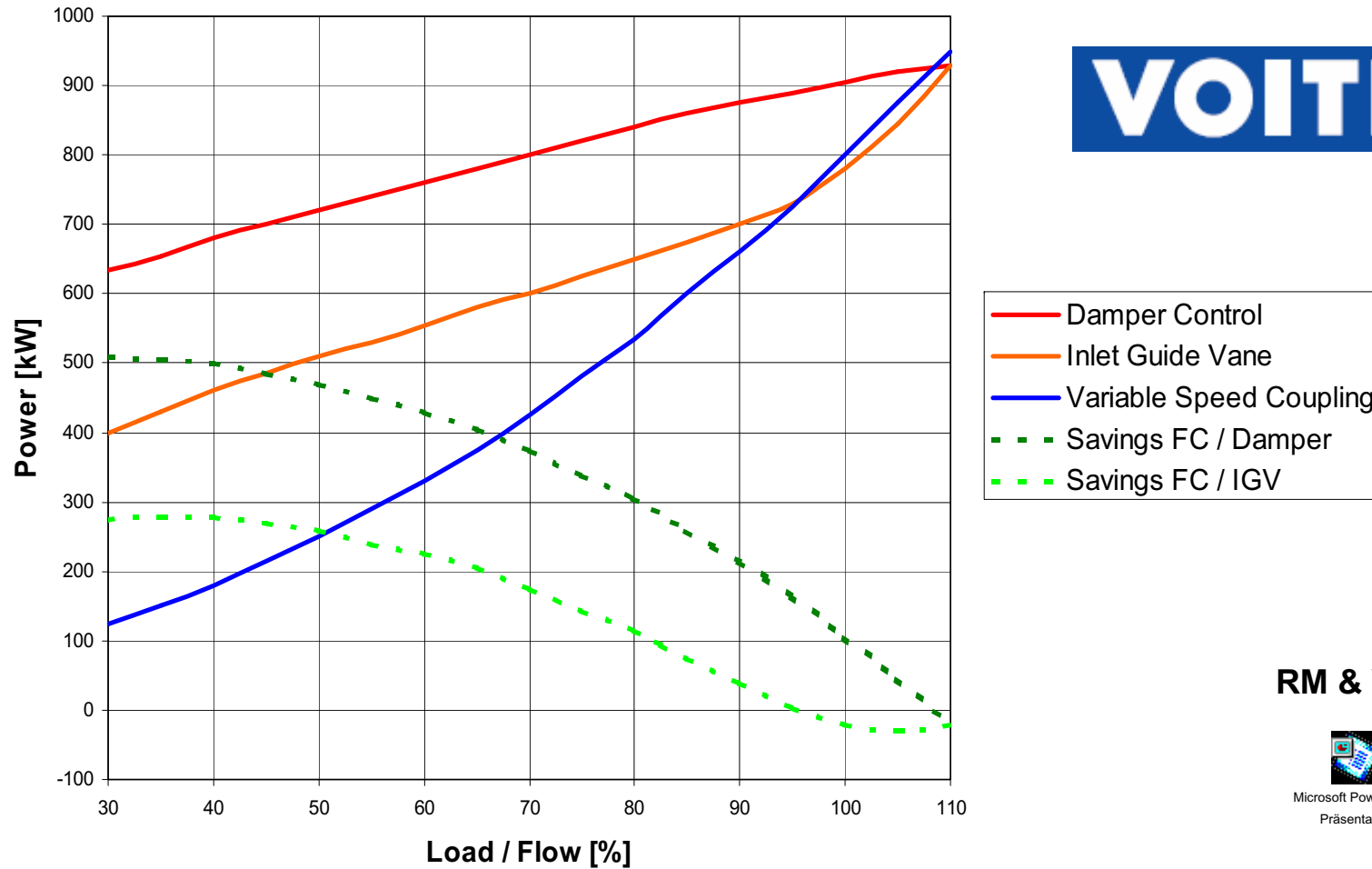

RM & Vorecon



Microsoft PowerPoint
Präsentation



- ▶ (4) 150 in. diameter airfoil bladed ID Rotors
- ▶ Forged double hubs
- ▶ Variable speed control via VFD
- ▶ Designed to retrofit into two different Competitor's Housings (Unit 1 and Unit 2)
- ▶ Model performance test in each housing
- ▶ Includes turnkey installation
- ▶ Installed in 2002 and 2003



▶ Centrifugal Fans

▶ Airfoil Blades

- Highest efficiency, non-overloading power curve, low noise
- Strongest design, clean or dirty gas capable

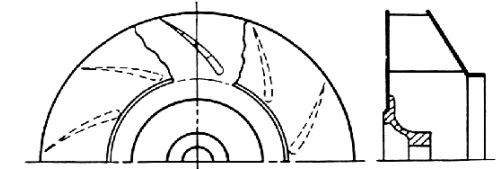

▶ Backward Curved Blades

- High efficiency, non-overloading power curve, low noise
- Single thickness blade, clean or dirty gas capable

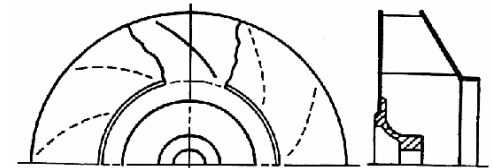

▶ Backward Inclined Blades

- Good efficiency, non-overloading power curve
- Single thickness blade, intended for high build-up service

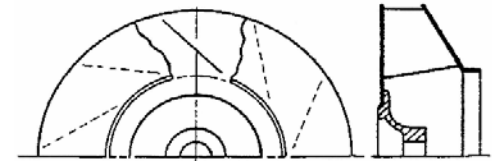

▶ Radial Tip Blades

- Lower efficiency, non-limit load power, higher noise
- Lower cost, intended for intense build-up or wear

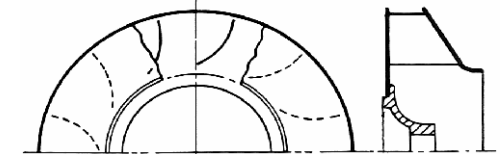

▶ Radial Blades

- Low efficiency, non-limit load power, higher noise
- Low cost, intended for high pressure, high speed service

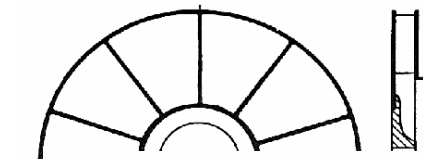

FläktWoods

Centrifugal Fan

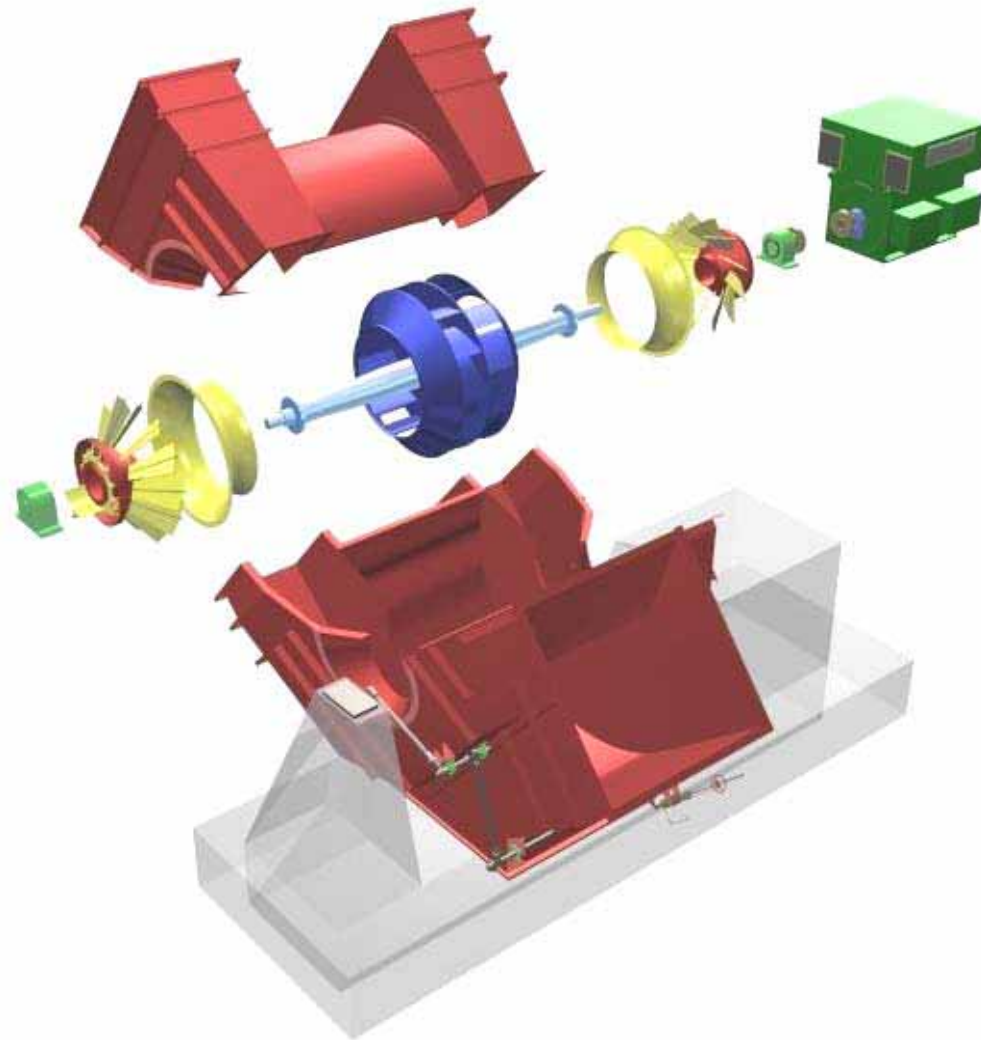

Impeller Protection - Aerofoil Bladed

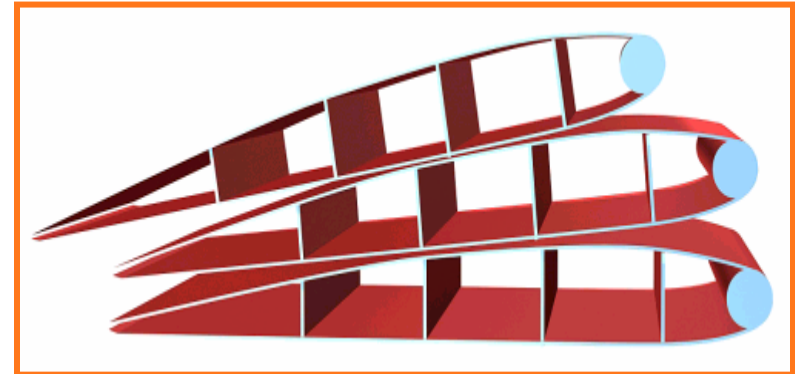
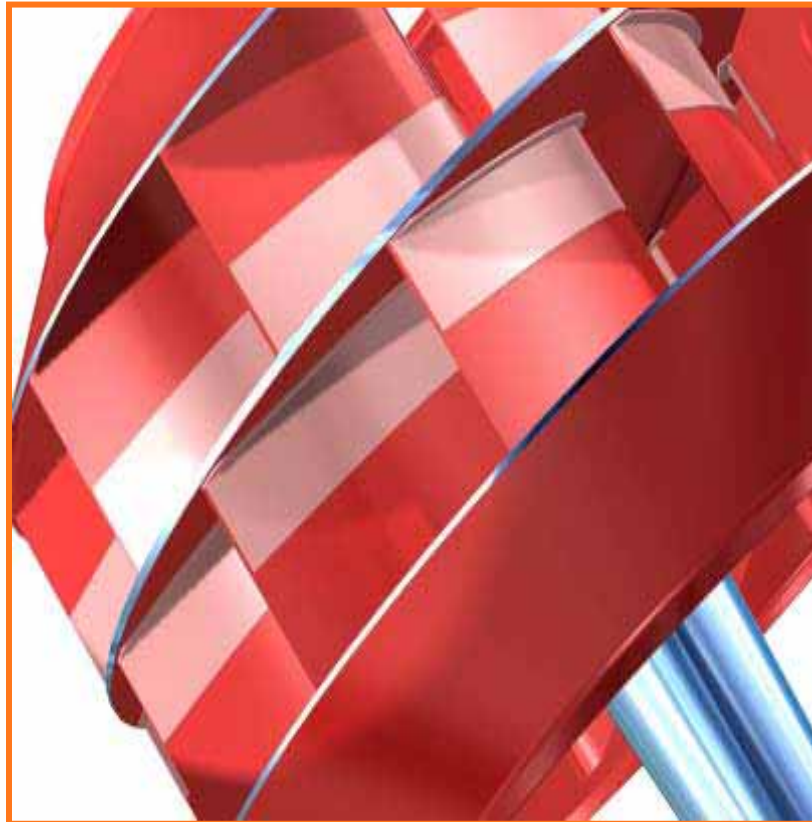

Inlet Vane Control



Inlet Louvre Dampers

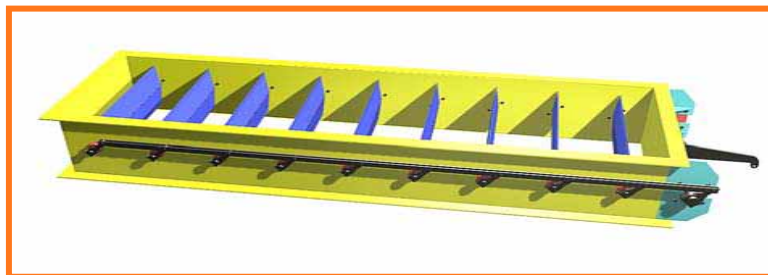
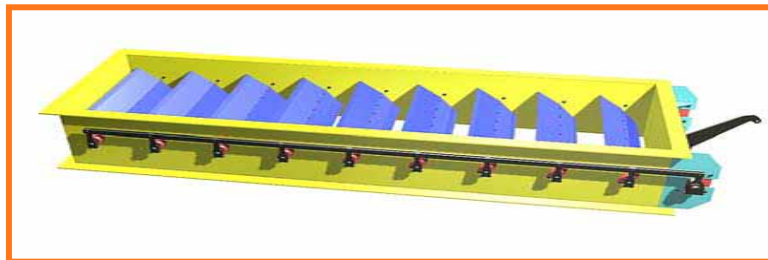
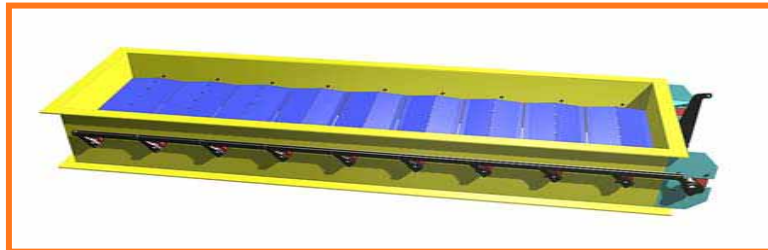

Shaft and Bearings



Balancing





- ▶ Finite element modal analysis

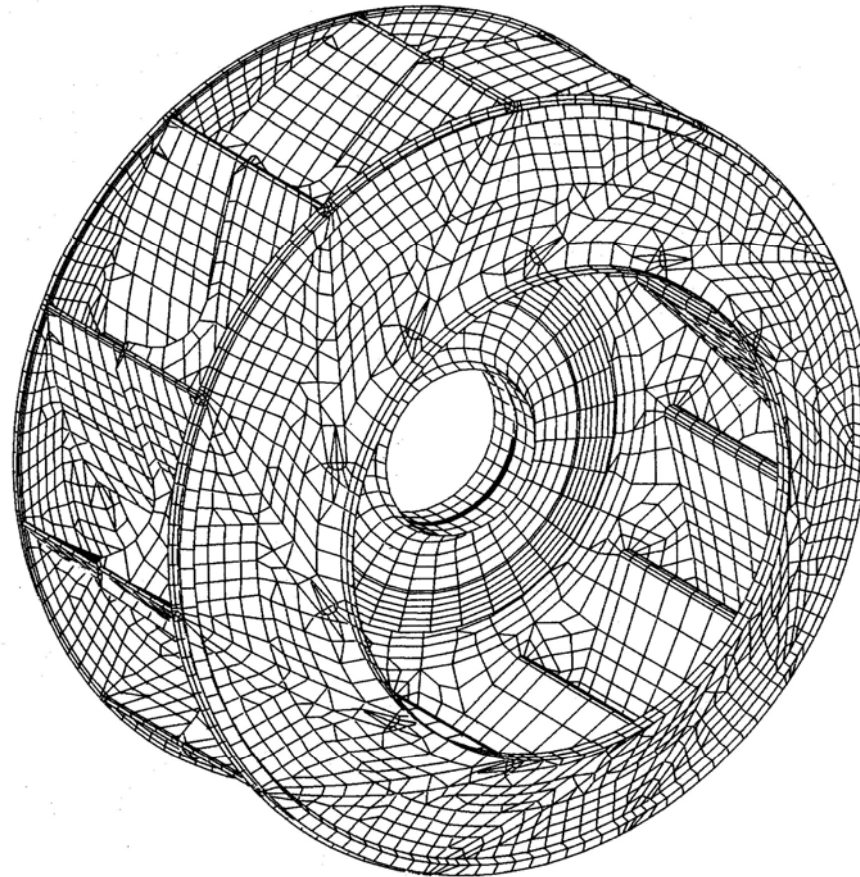

RUSH ISLAND 139.4" WHEEL
FULL MODEL FOR NATURAL FREQUENCY CALCULATIONS





- ▶ Variable pitch blades

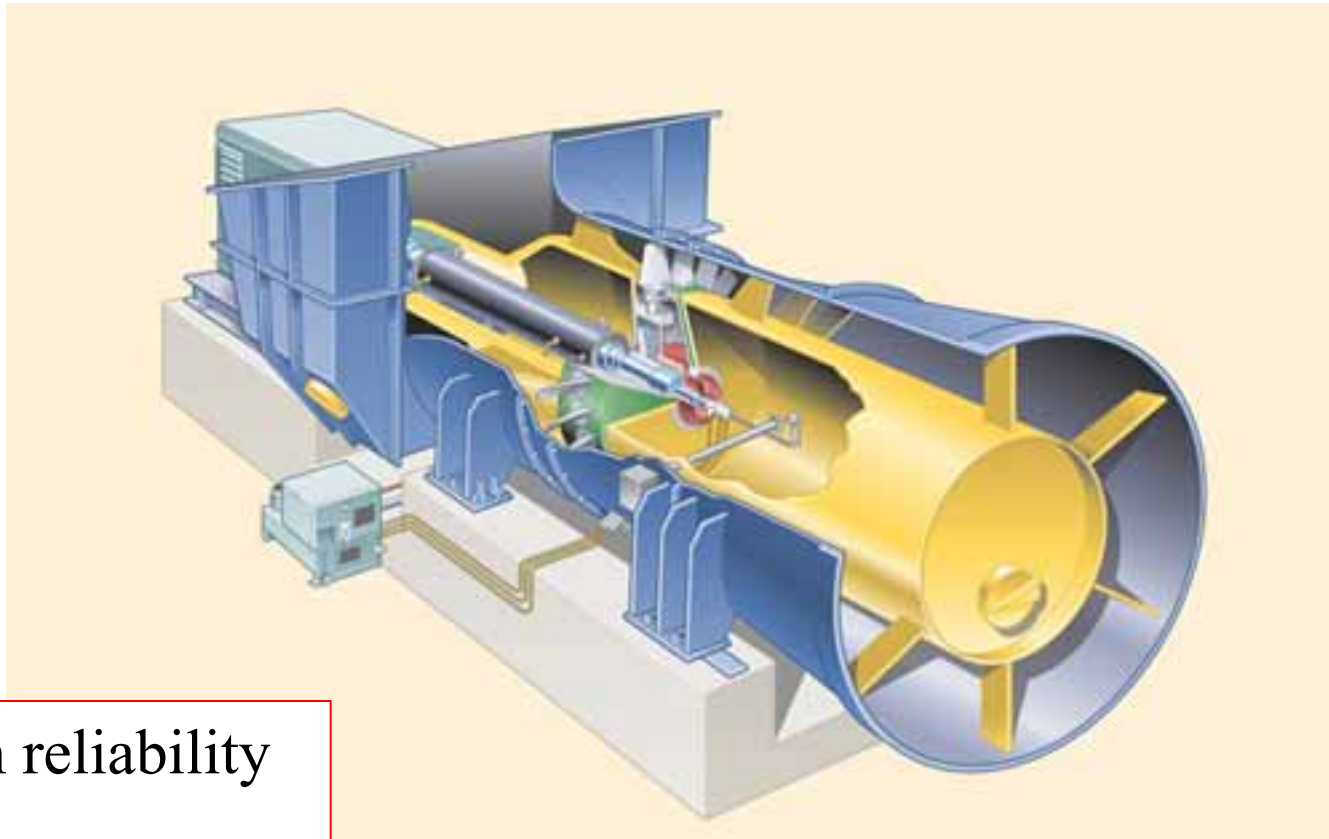

High reliability
High efficiency



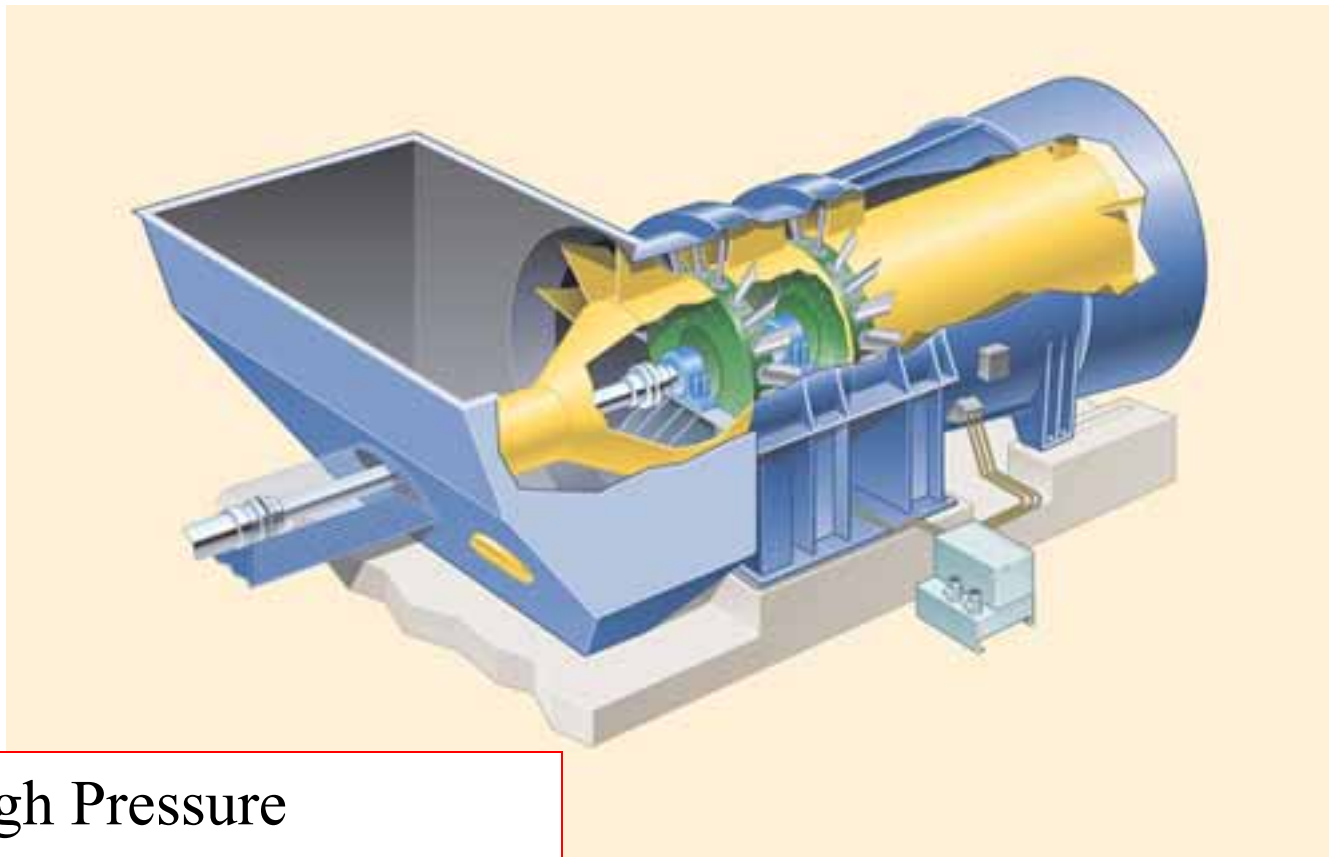

High Pressure
Compact design



Prepared for FGD or SCR



The use of VARIAX
flexible
guide vanes and medium
pressure profile secures
easy replacement to high
pressure profile when
implementing FGD or
SCR

The medium-pressure
profile with duty points
BEFORE FGD or SCR

The high-pressure
profile with duty points
AFTER FGD or SCR

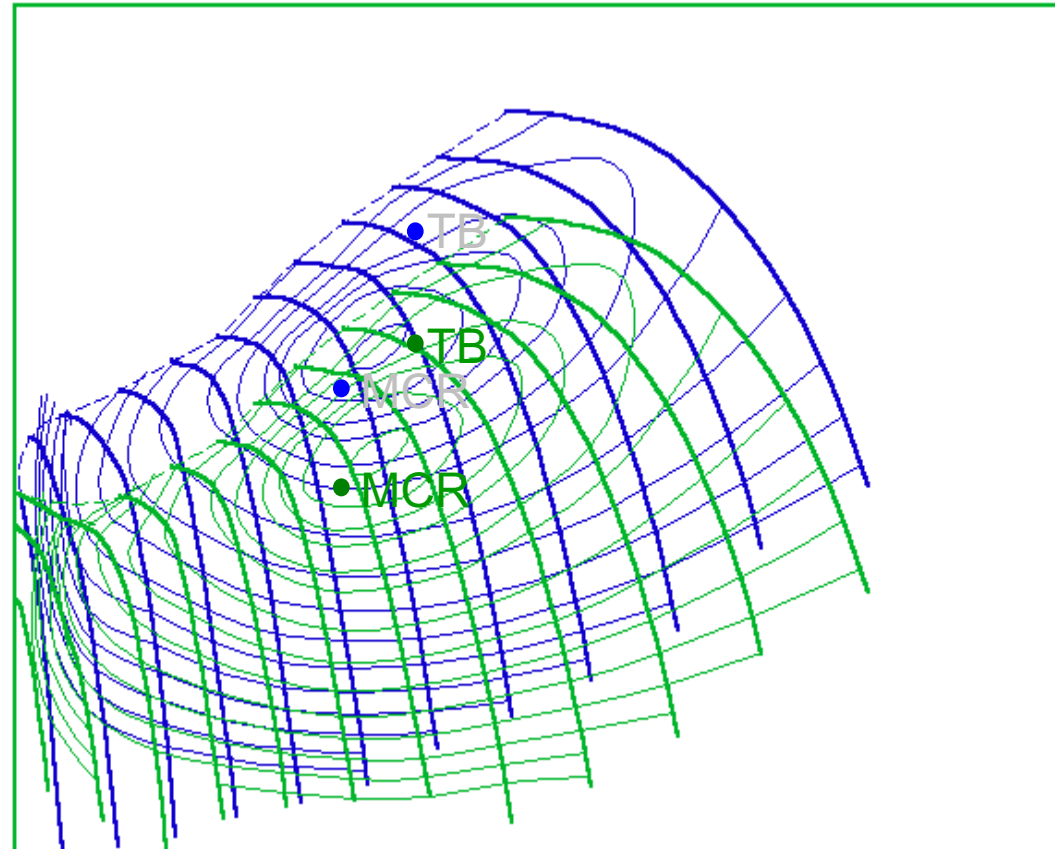

Types of The Variax[®] Fan



Variax[®] Type ANN Single-stage fan

Pressure up to 45-50 inwg

Volume flow up to 3.000.000 acfm

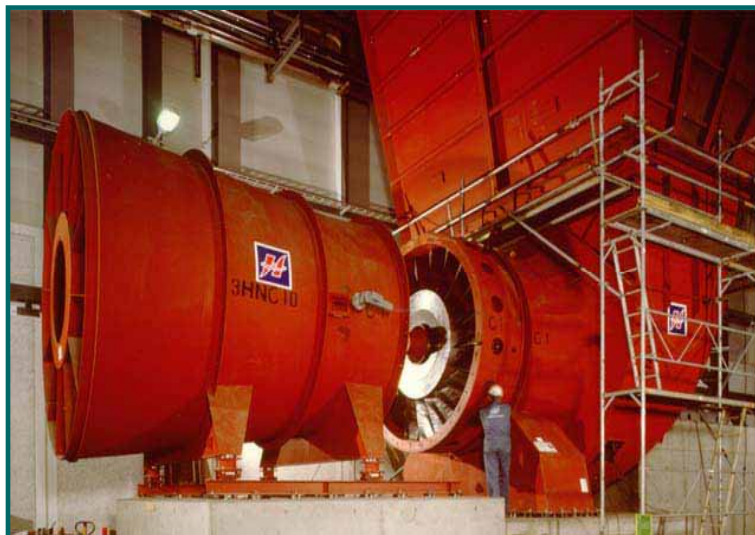

Variax[®] Type ANT Two-stage fan

Pressure up to 90-100 Inwg

Volume flow up to 3.000.000 acfm



Two-stage Axial Flow Fan

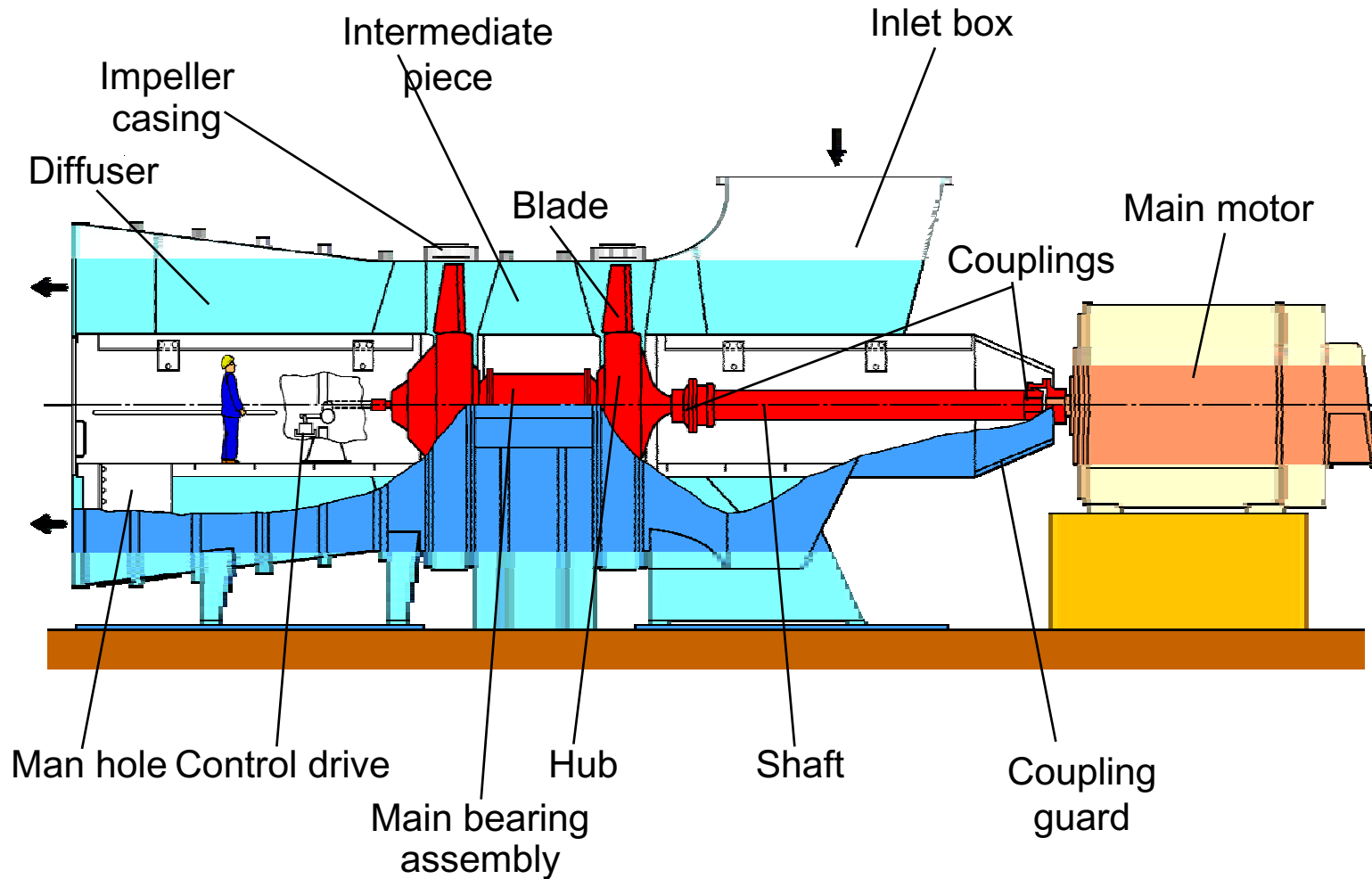



- ▶ Expansion joints – FSA – Fluid Sealing Association
- ▶ Dampers – AMCA - Air Movement and Control Association Inc.
- ▶ Fans – AMCA and ASME PTC 11 Fans