



Advanced Precipitator Fundamentals

By: Peter Aa
EPSCO International





Field charging as function of current

For field charging the saturation charge q_s of a spherical particle in a uniform electrical field E is [1,12]:

$$q_s = n_s e = \frac{12 \pi \epsilon_0 \epsilon}{\epsilon + 2} E a^2$$

with:

e : elementary charge, n_s : number of charges in saturation, a : particle radius.

The time development from charge zero to saturation charge in a uniform ion density region can be described as follows [1]:

$$q(t) = q_s \frac{t}{t + t_0}$$

with the characteristic charging time

$$t_0 = \frac{4 \epsilon_0}{N e K},$$

where N denotes the ion density and K the ion mobility.

The ion density of single charged ions is related to the current density according to [1]:

$$j = N e K E$$

and t_0 can therefore be expressed with the measurable parameters j and E :

$$t_0 = 4 \epsilon_0 \frac{E}{j}.$$

Thus the field charge as function of time, current density, and electric field can also be written as:

$$q(t) = \frac{3 \epsilon}{\epsilon + 2} \pi a^2 \frac{1}{\frac{1}{4 \epsilon_0 E} + \frac{1}{j t}}$$

Advanced Precipitator Fundamentals

- ◆ Gas Flow Distribution
- ◆ Gas Flow Sneakage
- ◆ Particulate Distribution
- ◆ Particle Size
- ◆ Electrical Sectionalization
- ◆ Rapping Density
- ◆ Rapping Re-entrainment
- ◆ Particulate Resistivity
- ◆ Voltage vs. Current Curves
- ◆ Electrode Management
- ◆ Wire Breakage
- ◆ Electrical Control Systems
- ◆ Hopper Problems
- ◆ Record Keeping

Gas Flow Distribution

Gas Flow Distribution

- ◆ Sizing and power requirements are based on each square foot of collecting area performing efficiently.
- ◆ Higher flows can result in reduced migration velocity, re-entrainment/ scouring.
- ◆ Lower flows can result in wasted power.

Poor Gas Flow Distribution

Poor Gas Flow Distribution

◆ Side to Side

- Tends to follow rotation of the air heater

◆ Top to Bottom

- Poor distribution plate/turning vane location/construction

◆ Outside In

- General poor duct design or vane type or location

◆ Inside Out

- General poor duct design or vane type or location

Poor Gas Flow Distribution

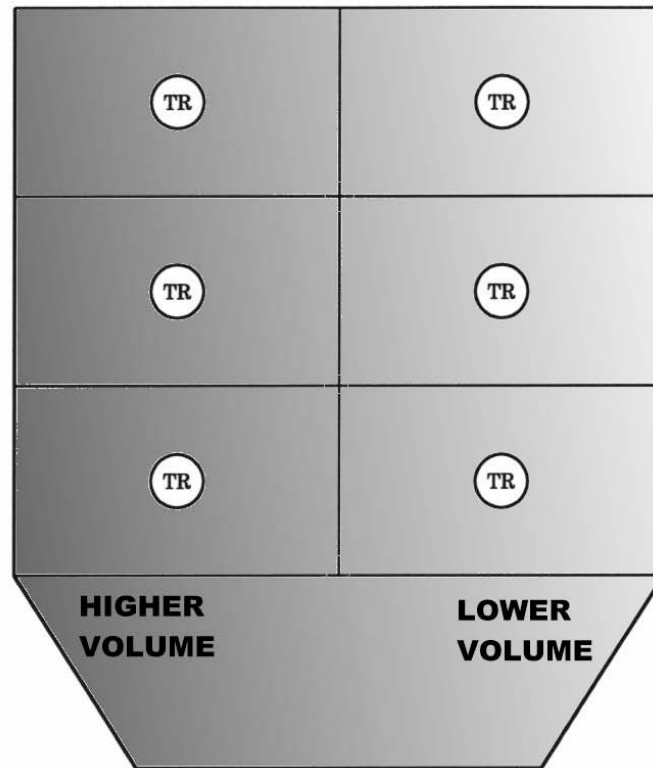

Gas Flow Distribution Devices

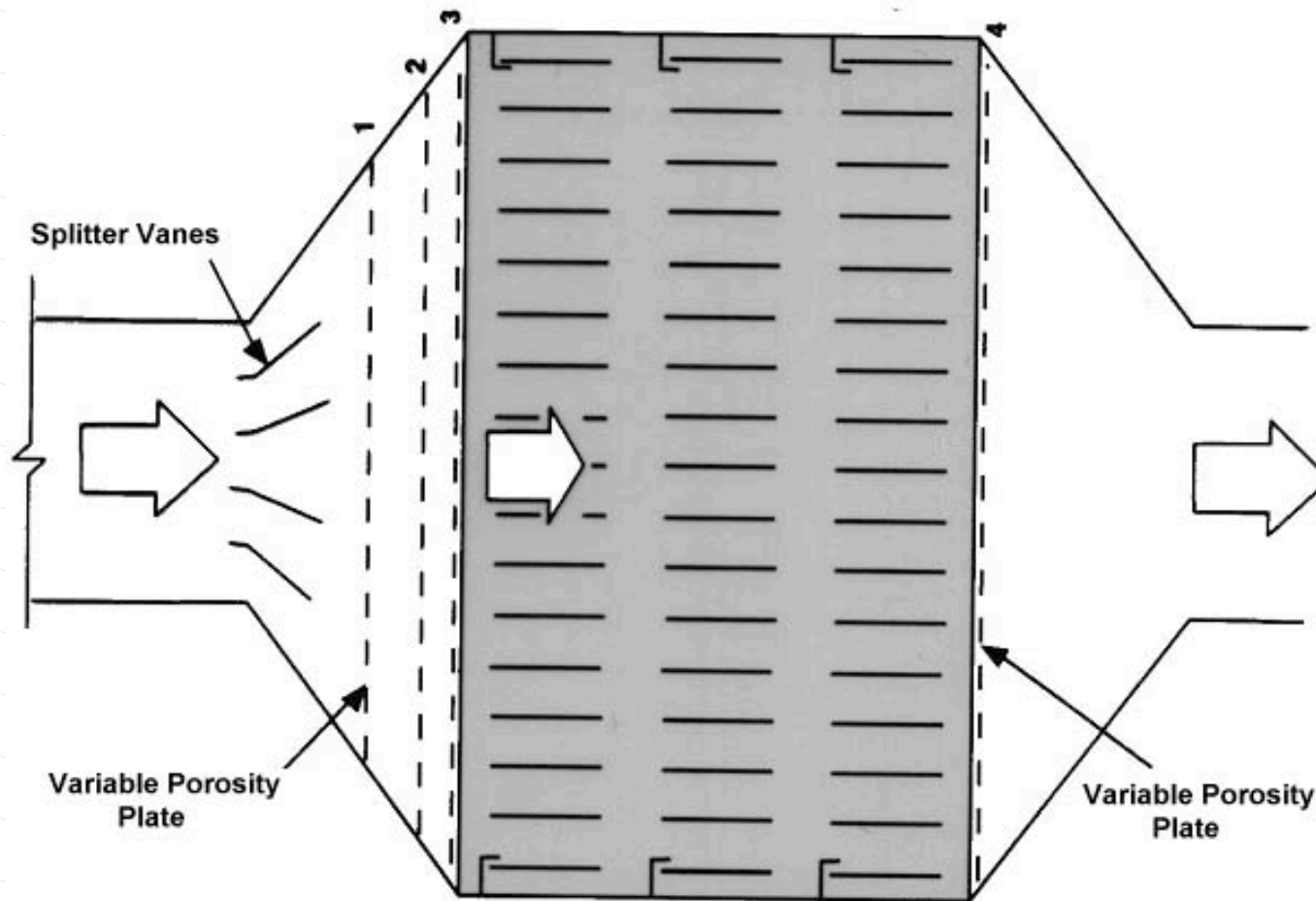

Gas Flow Distribution Devices

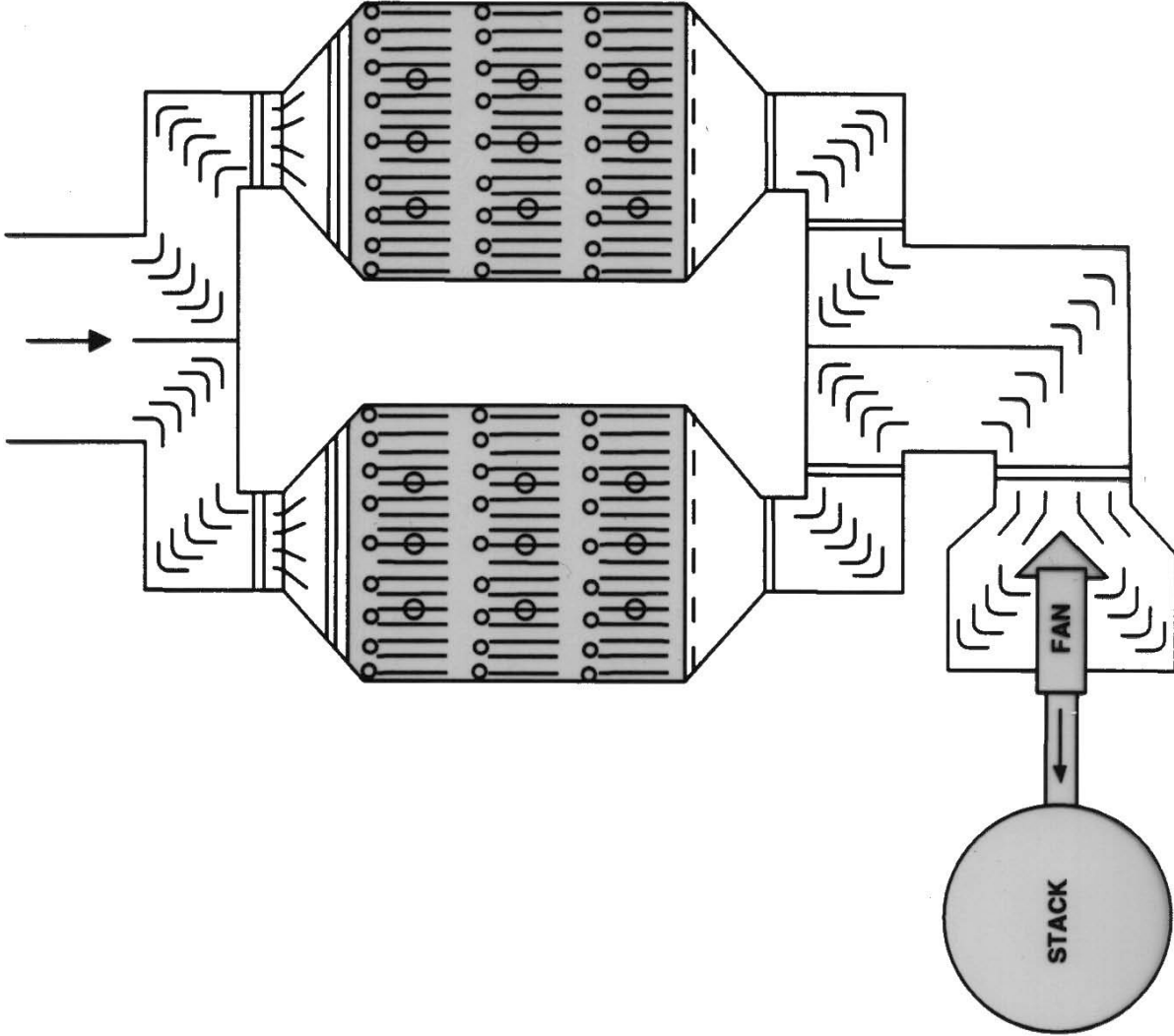

Gas Flow Sneakage

Gas Flow Sneakage

◆ Gas Flow Outside the Treatment Zone Reduces Precipitator Efficiency

◆ Types of Sneakage

- Over the top
- Under the bottom
- Around the sides
- Up the sides
- Through the hoppers

Over and Under Sneakage

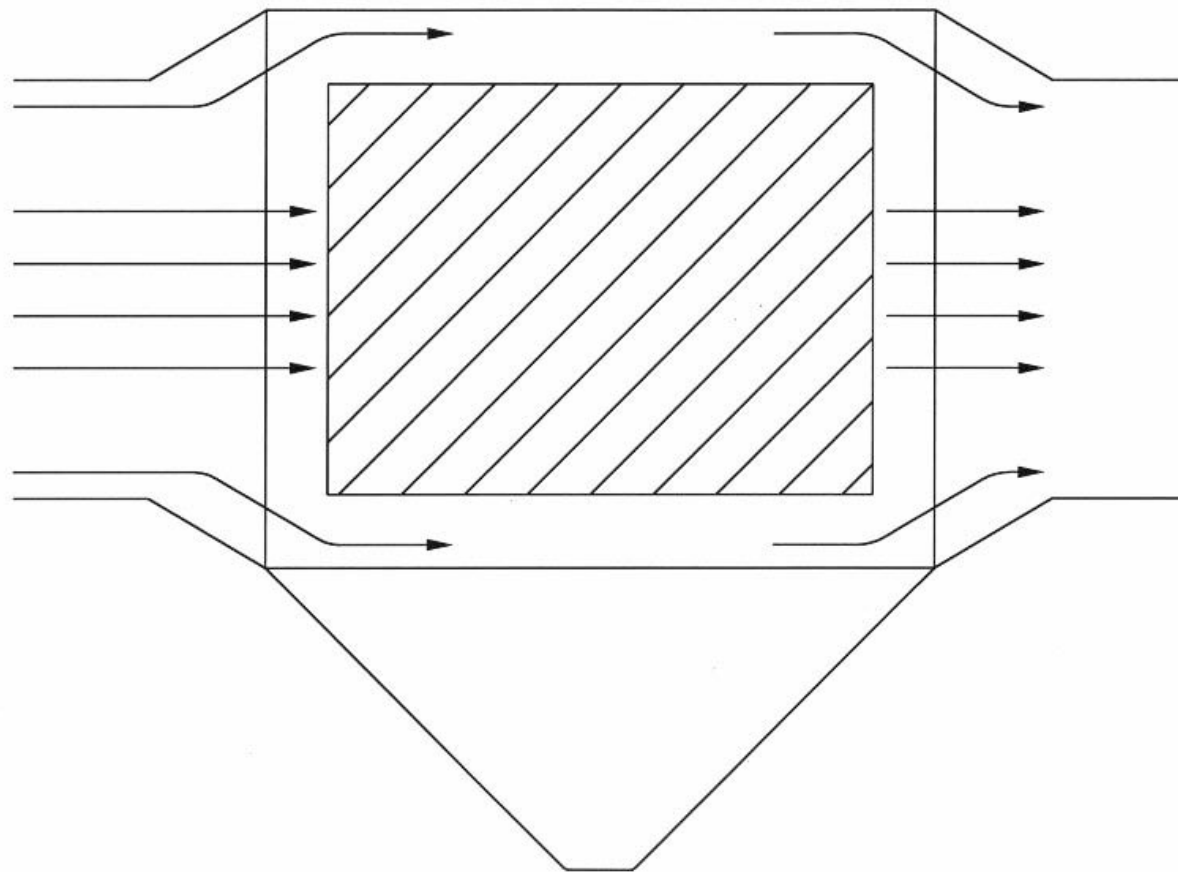

Severe Under Sneakage

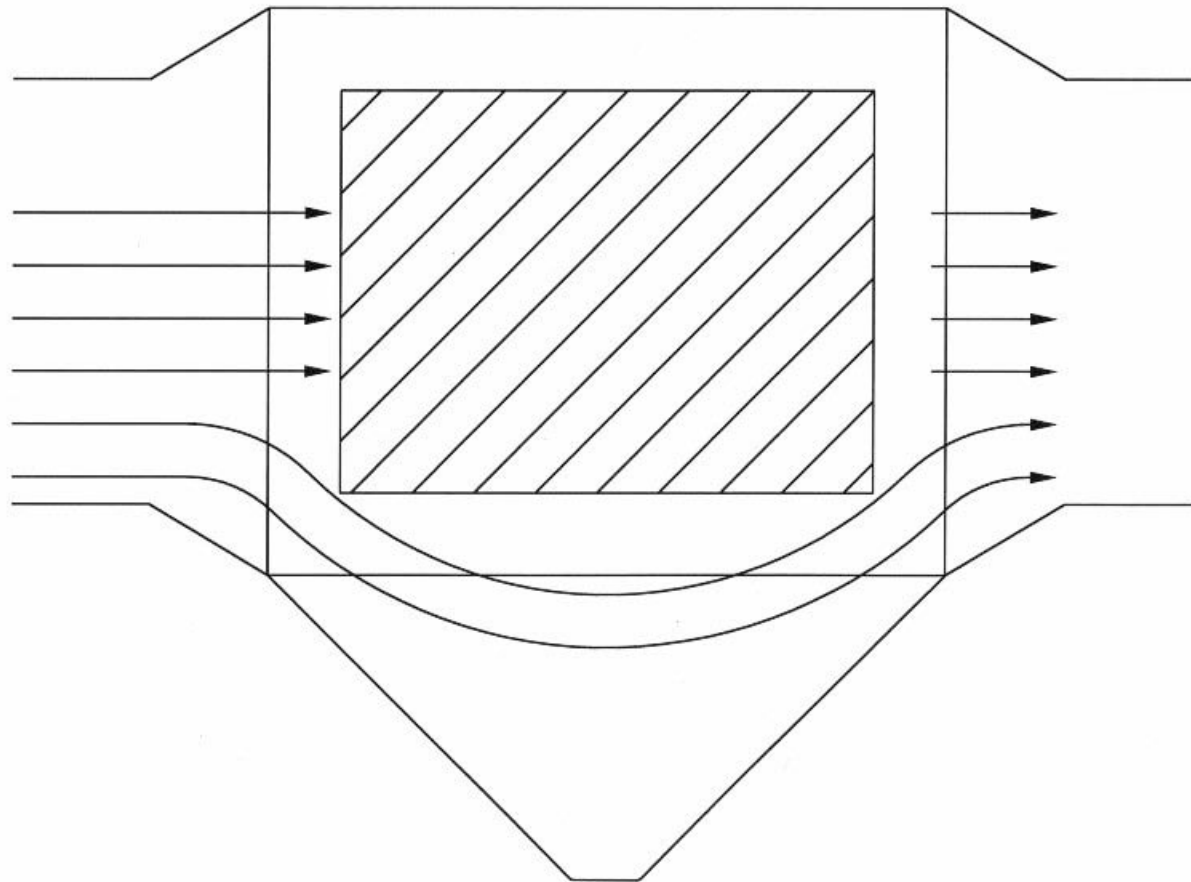

Side Sneakage

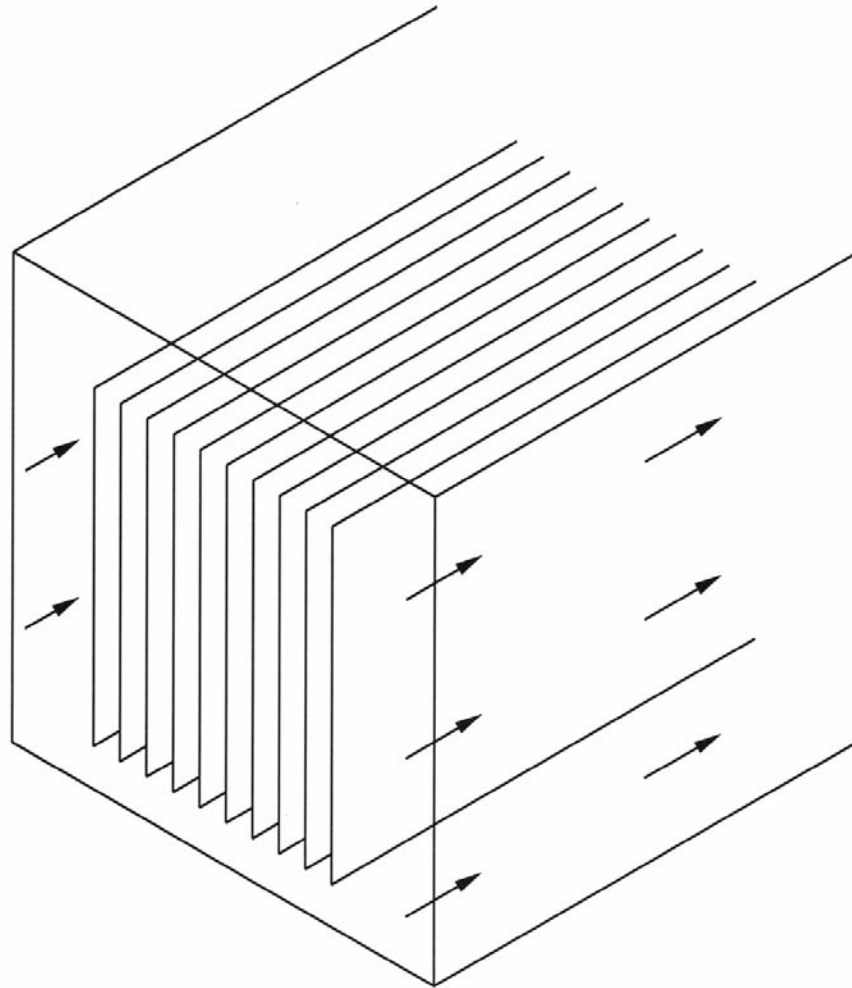

Vertical Sneakage

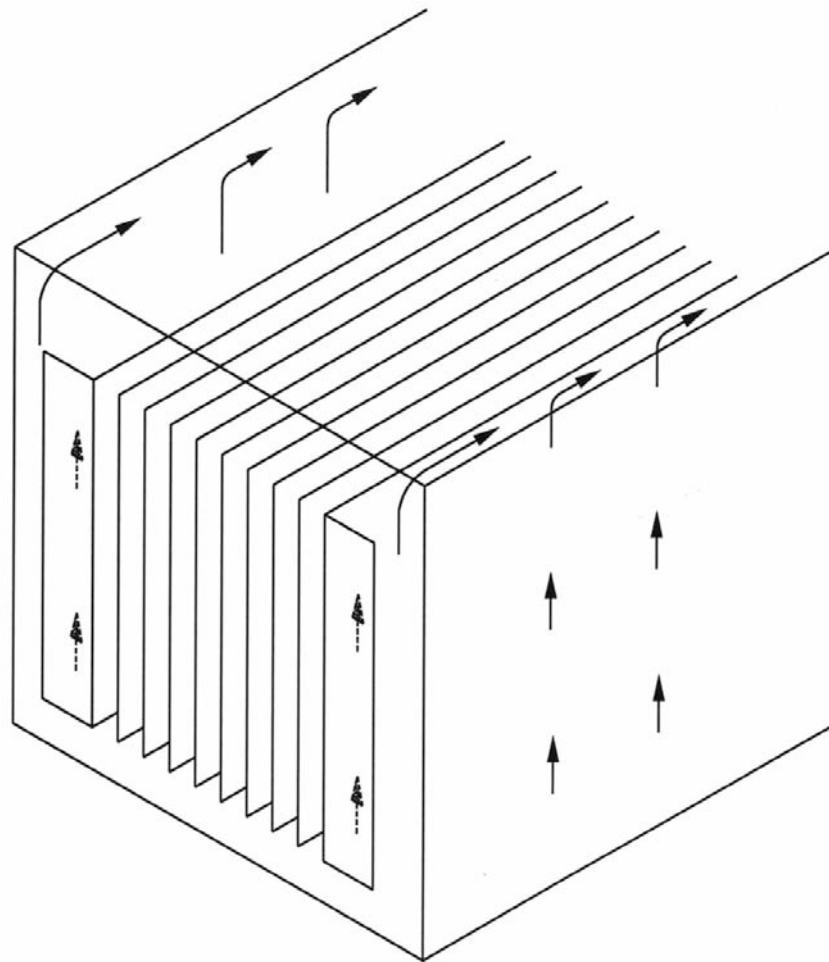

Snaking Hopper Flow

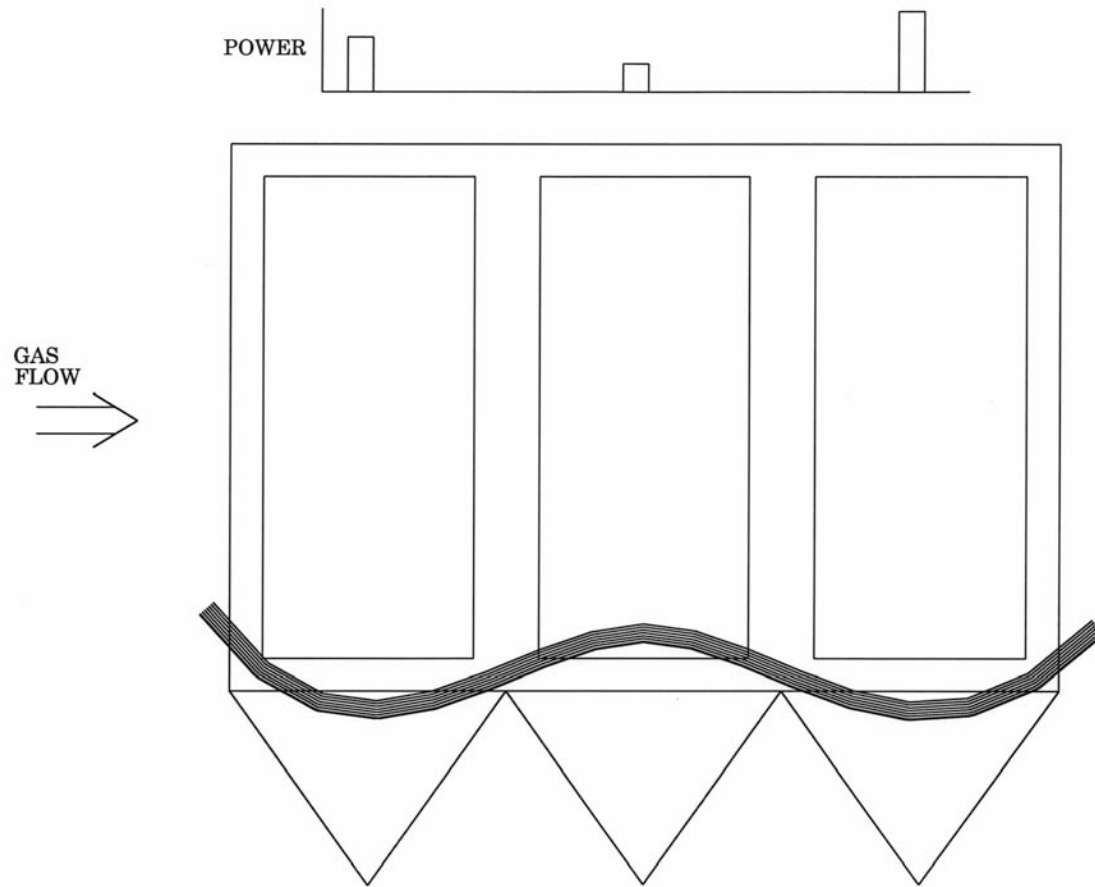



Particulate Distribution Uniformity

Particulate Distribution Uniformity

- ◆ Particulate Distribution Does Not Necessarily Follow Gas Distribution
- ◆ Heavier Particles Tend not to Follow Turns in the Gas Stream
- ◆ Small Particles are Carried by the Gas Stream

Particulate Distribution Uniformity

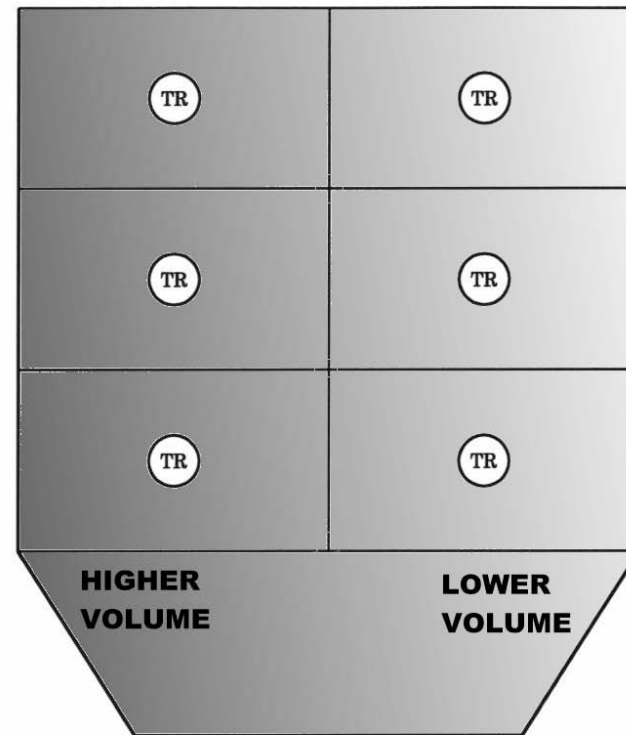
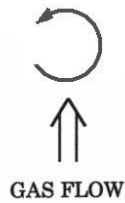
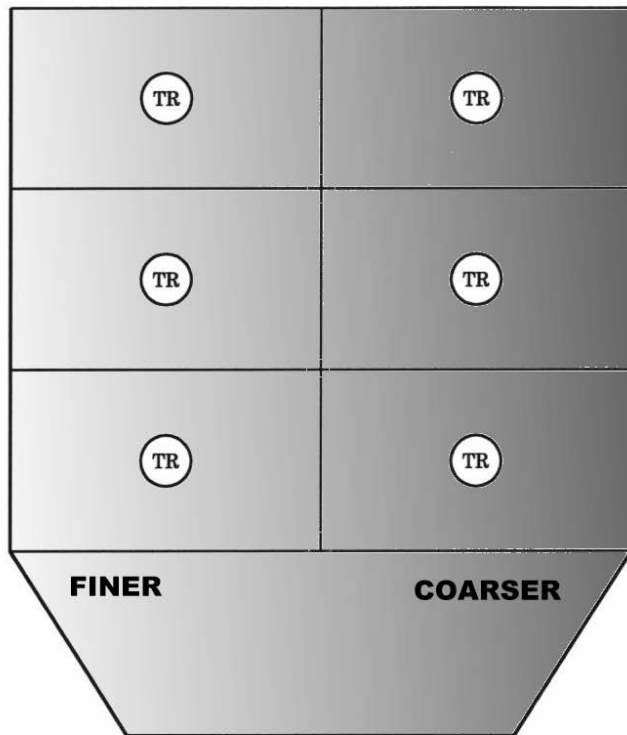

Particle Size Effect on Opacity

Particle Size Effect on Opacity

- ◆ For the Same Emissions by Weight
 - large size particles will show a lower opacity because they attenuate less light.
 - small size particles will show a higher opacity because they attenuate more light.

- ◆ What Changes Particle Size?
 - Coal characteristic
 - Grinding of the coal
 - Firing of the coal

Particle Size Effect on Collection

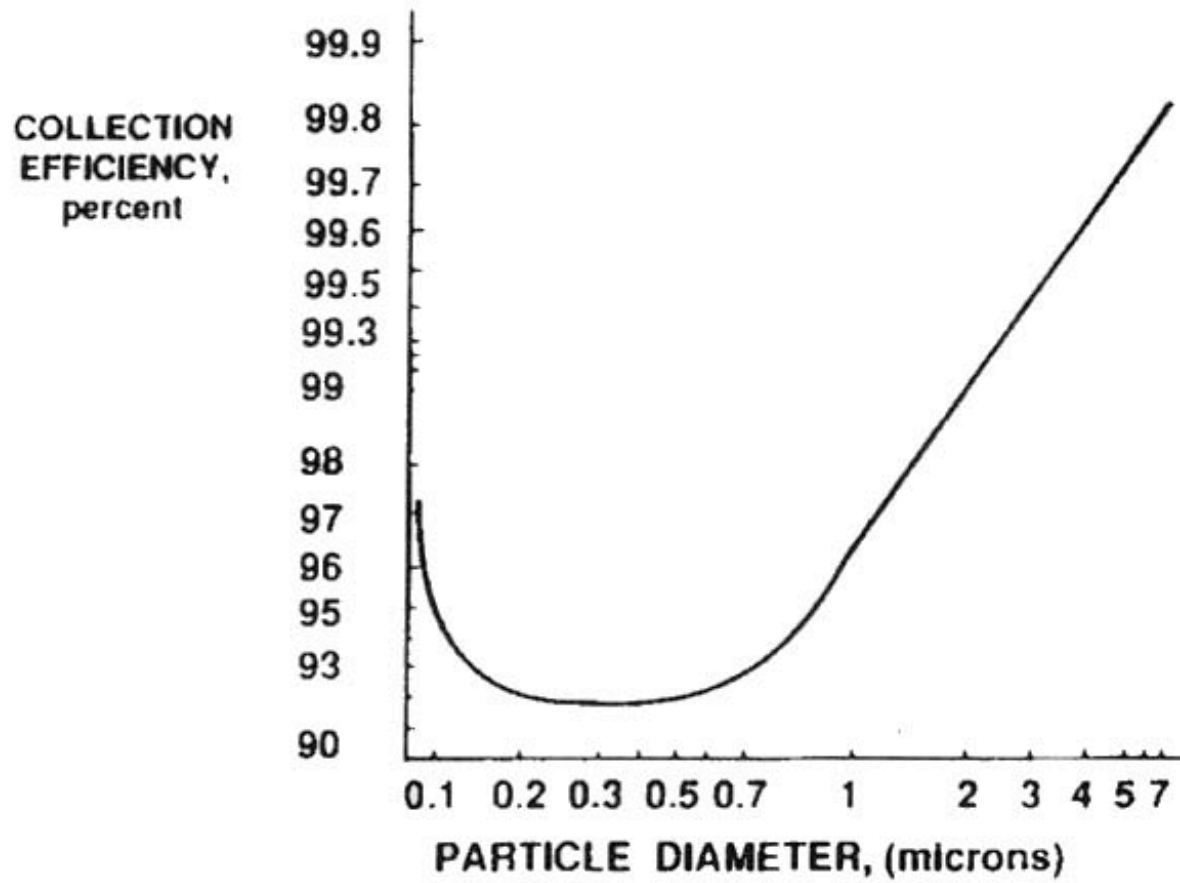

Correction Methods

- **Field Test**
- **Computer Model Study**
- **Physical Model study**



Electrical Sectionalization

Electrical Sectionalization

◆ A High degree of Electrical Sectionalization Reduces the Effect of:

- Broken Electrodes
- Close Clearances
- Full Hoppers
- Tracked Insulators
- Poor Particulate Distribution

Electrical Sectionalization

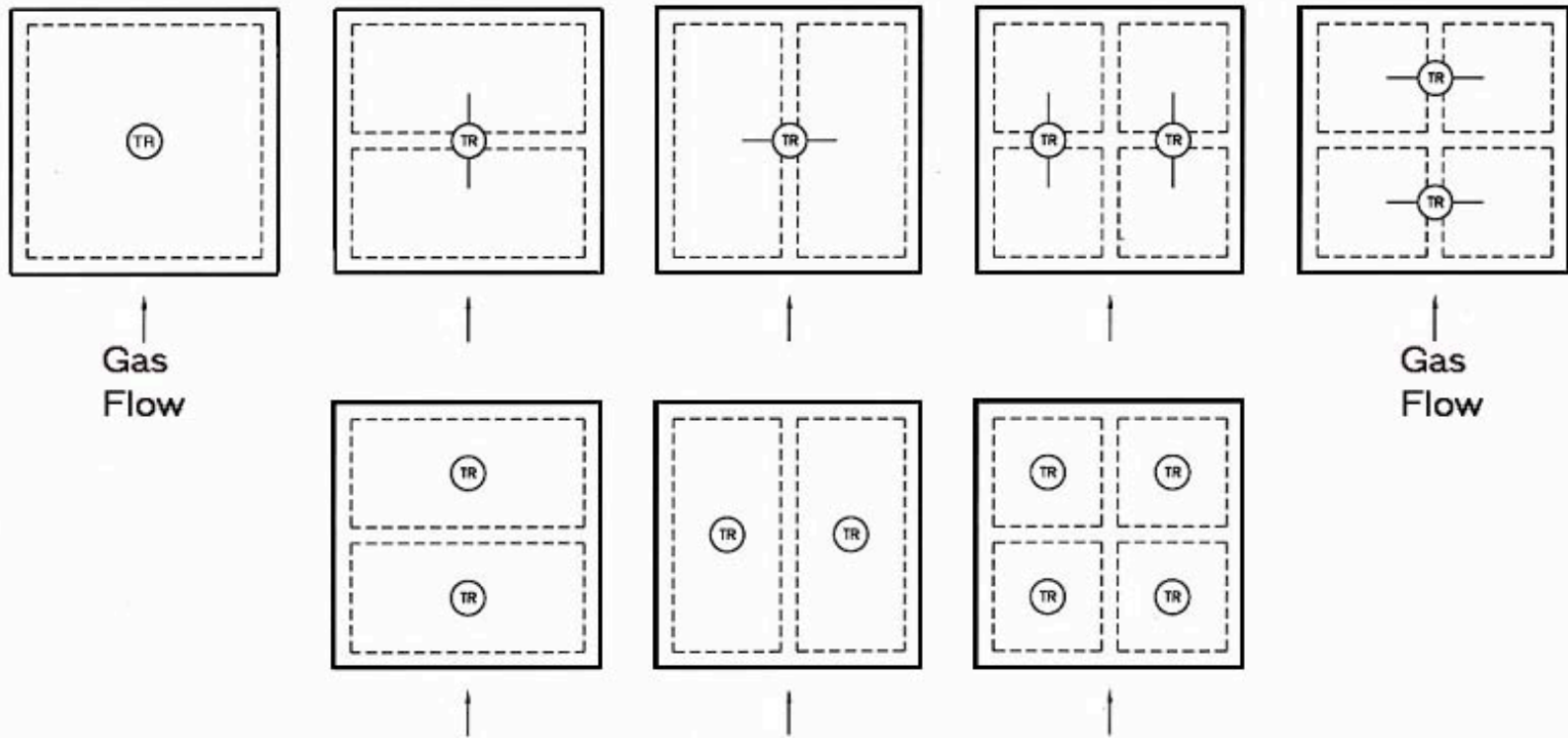

Electrical Sectionalization

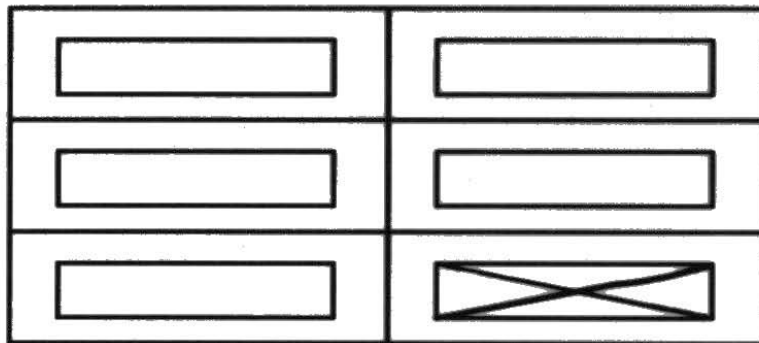

Installed SCA

300

99%

**SCA with One
Bus Section Lost**

250

93.5%

Electrical Sectionalization

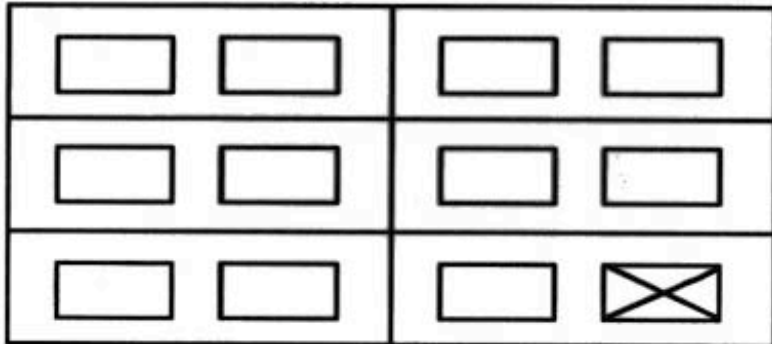

Installed SCA	SCA with One Bus Section Lost
<hr/>	<hr/>
300	275
99%	97.5%

Electrical Sectionalization

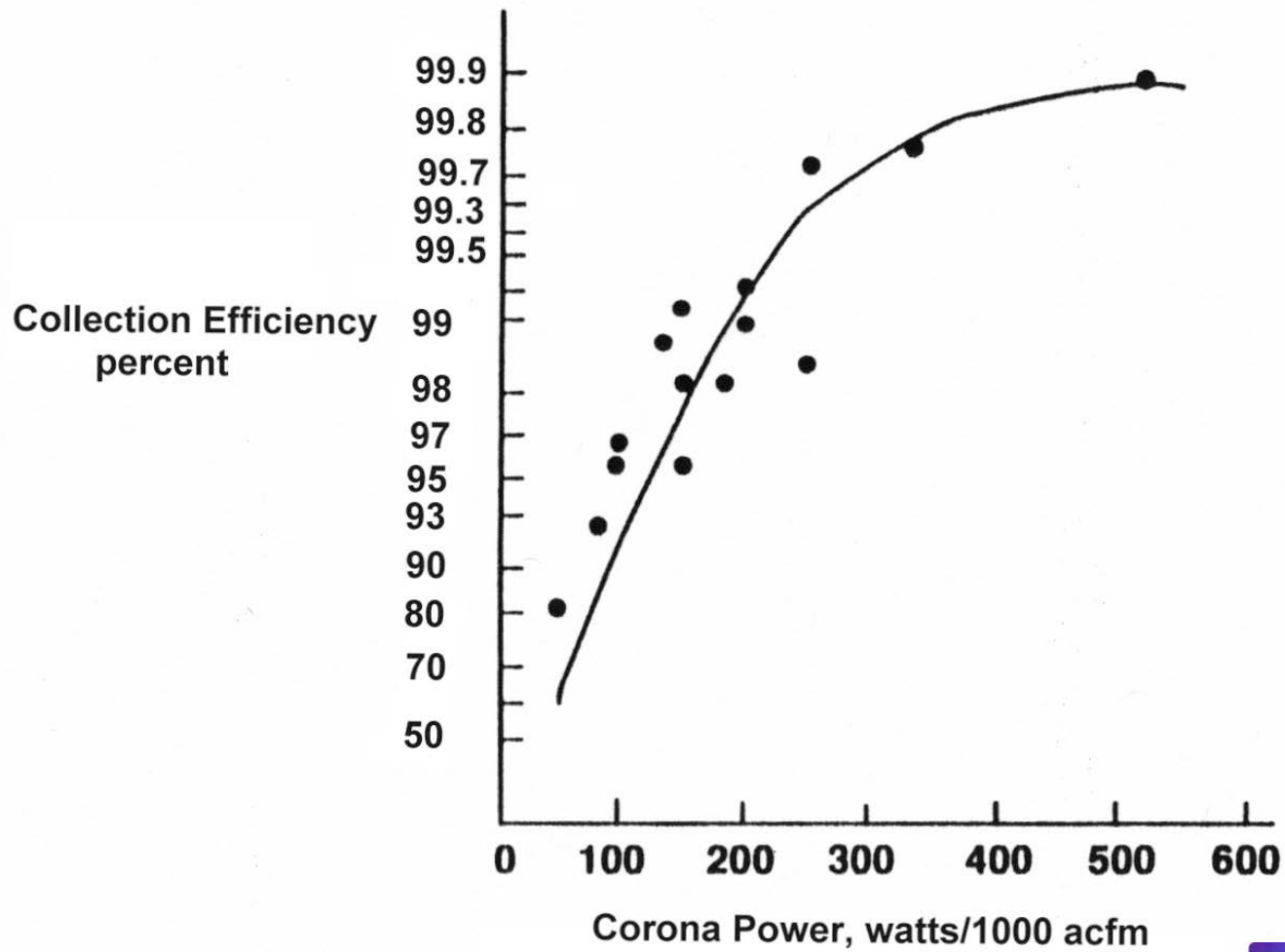

Rapping Density

Rapping Density

- ◆ Rapping density is the square feet of collecting electrode or linear feet of discharge electrode cleaned by one “rapper”.

- ◆ Too High a CE Rapping Density Results in:
 - Clean plates below the point of impact
 - Dirtier plates at the outboard areas
 - Re-entrainment of particulate when rapping energy is increased to keep outboard plates clean

- ◆ Too High a DE Rapping Density Results in:
 - Corona suppression

Rapping Density

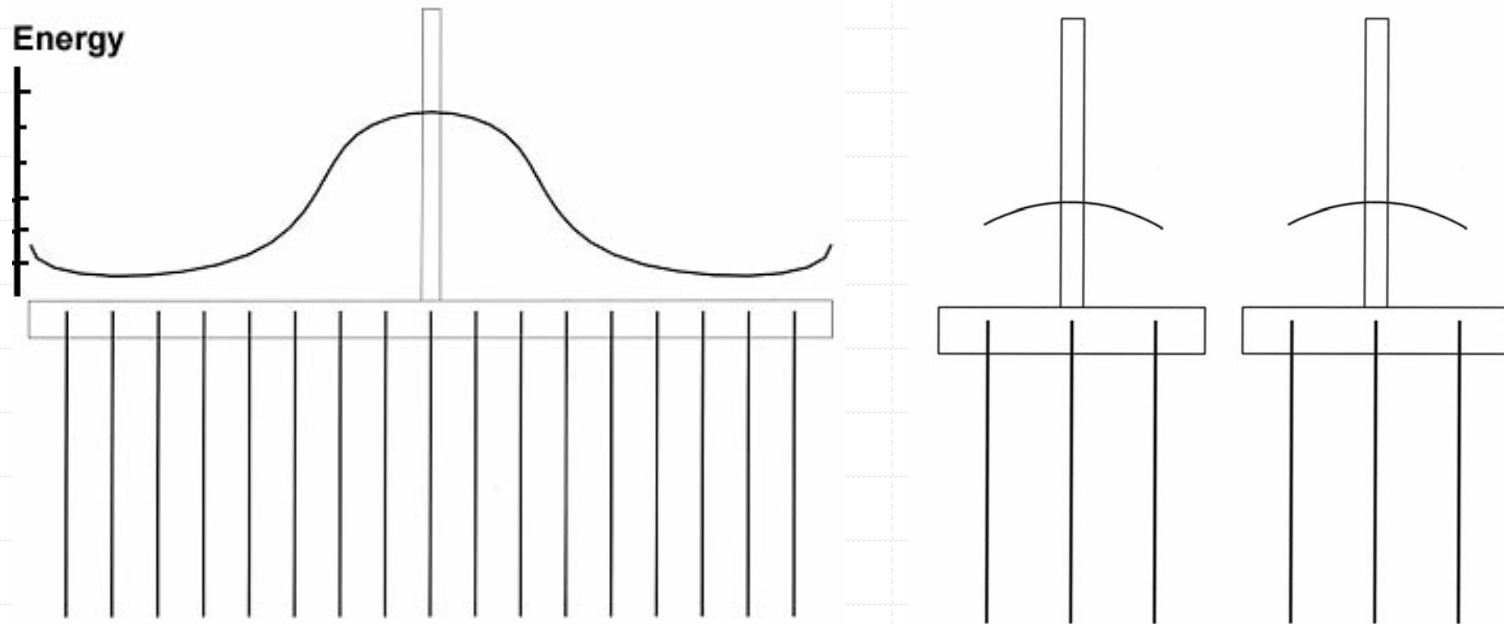

Rapping Re-entrainment

Rapping Re-entrainment

- ◆ Rapping Too Often Prevents Agglomeration
 - Results in continuous re-entrainment and elevated opacity/emissions

- ◆ Rapping Too Hard Causes Lateral Release
 - Results in spiking/puffing, especially towards the outlet where there is no backup field

- ◆ Optimization - Trial and Error - Experience

Rapping Re-entrainment

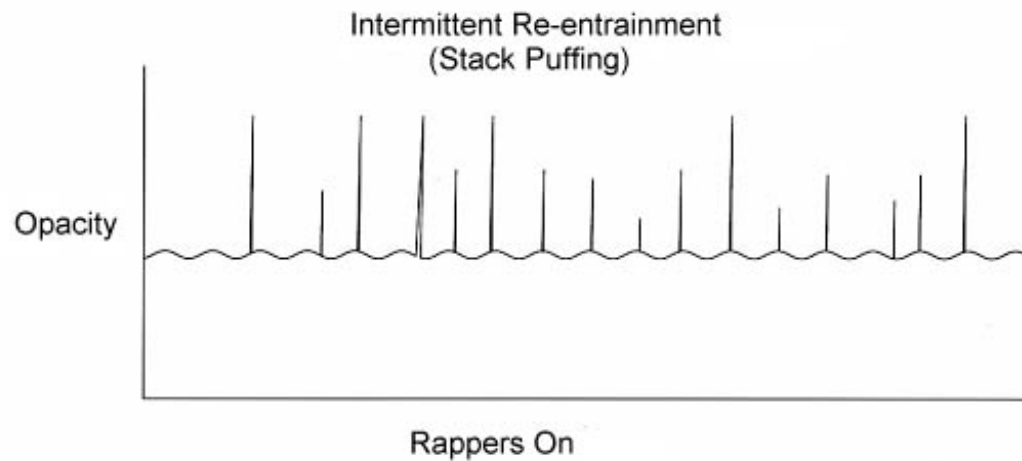
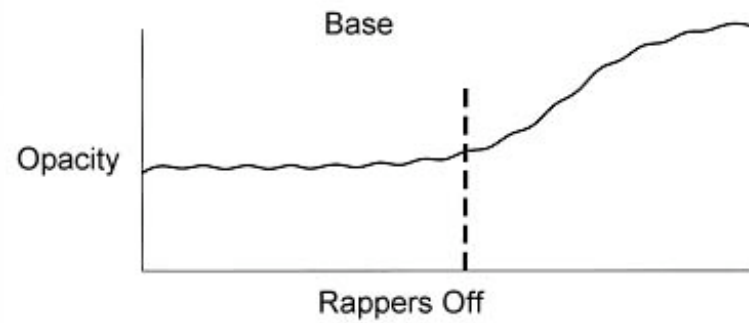
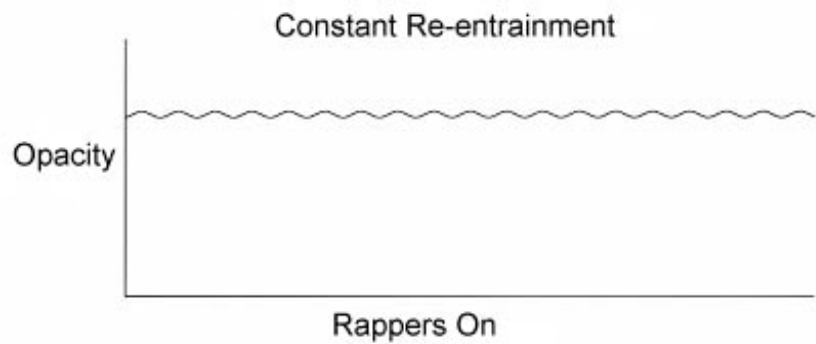

Rapping Re-entrainment

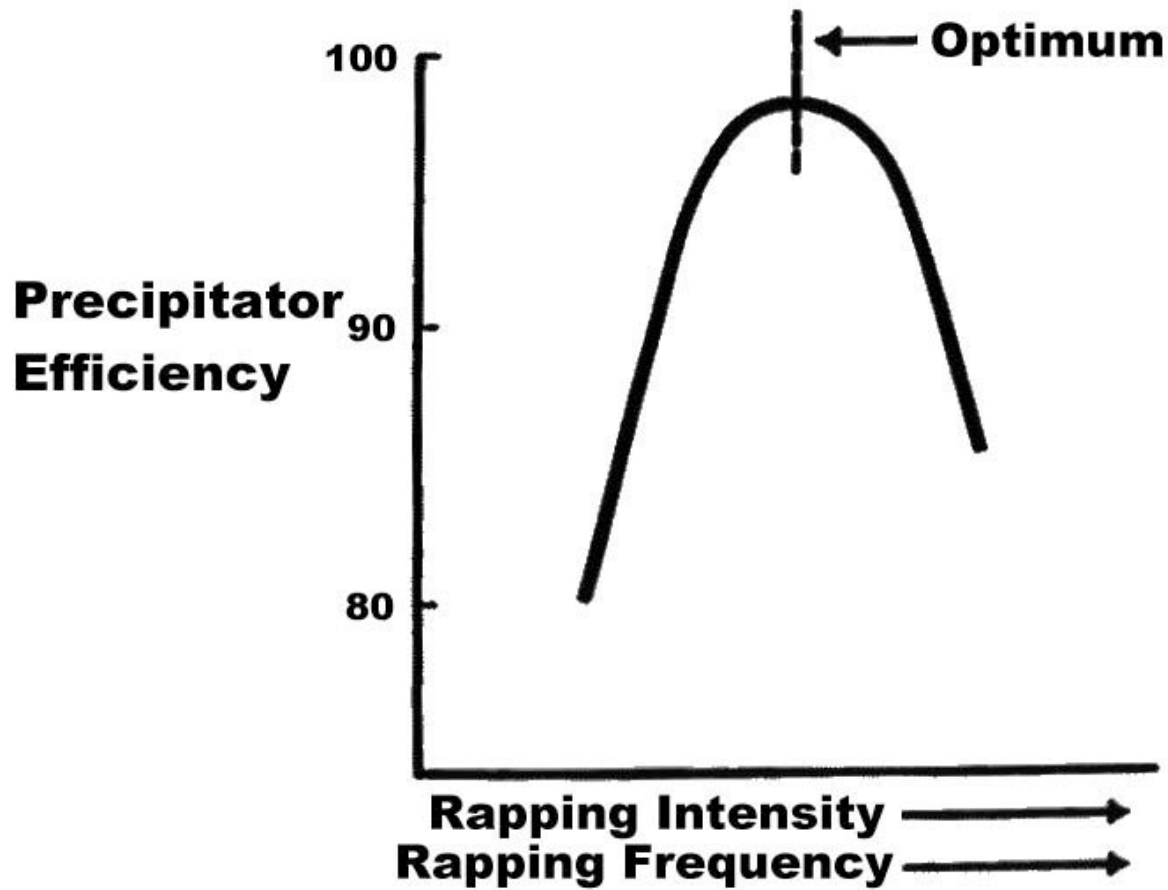

Particulate Resistivity

Particulate Resistivity (High)

◆ For a Given Precipitator Size (SCA)

- The higher the particulate resistivity the harder it is to charge an ash particle
- The higher the particle resistivity the more energy required to clean the collecting plates and the more frequent the cleaning is required
- The higher the particle resistivity the lower the precipitator efficiency (and the higher the outlet emissions)

Particulate Resistivity (Low)

◆ For a Given Precipitator Size (SCA)

- The lower the particulate resistivity the higher the the spark over voltage
- The lower the particle resistivity the less energy required to clean the collecting plates and the less frequent the cleaning is required
- For very low particle resistivity the lower the efficiency (and the higher the outlet emissions)

Particulate Resistivity

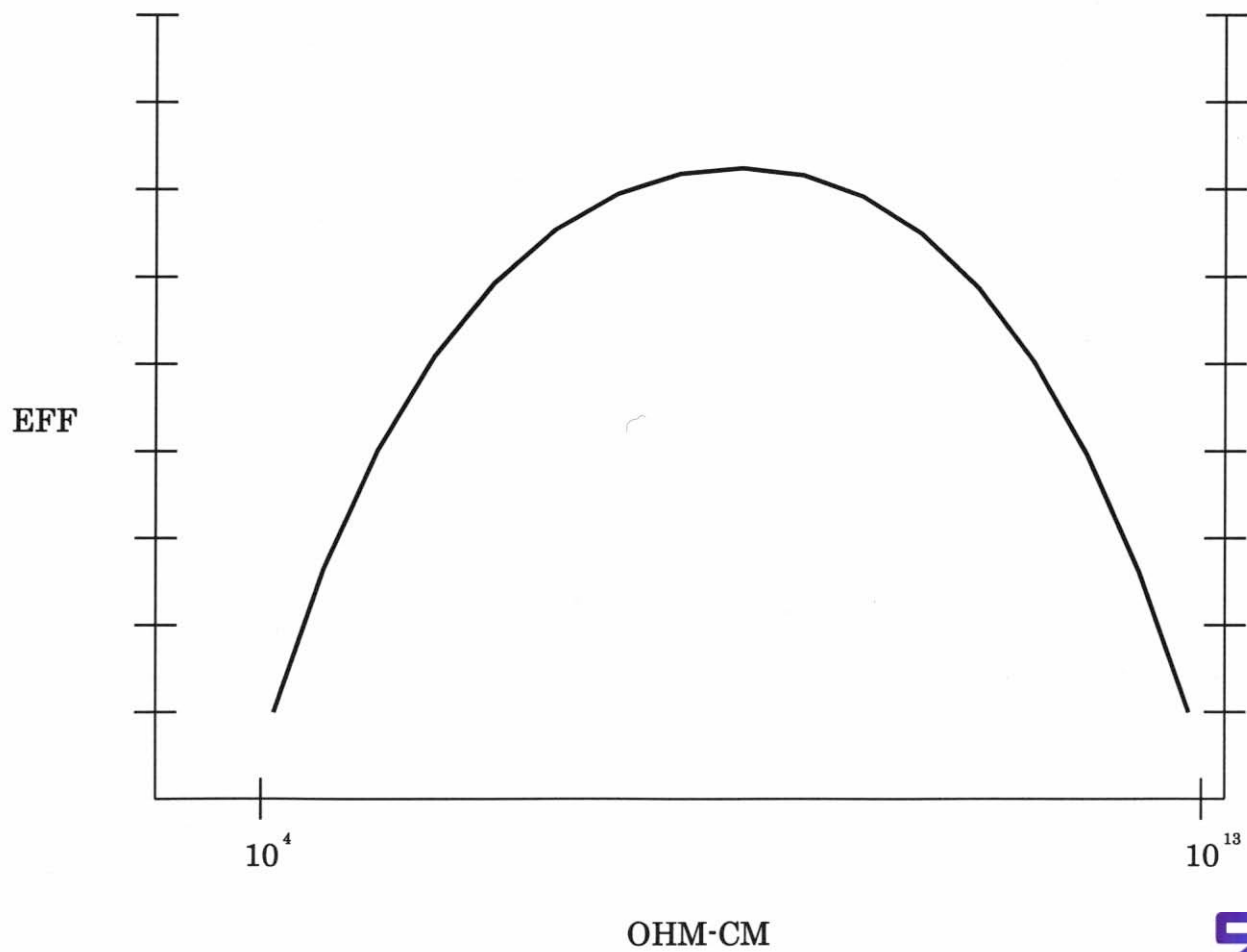

Voltage vs. Current (VI) Curves

Voltage vs. Current (VI) Curves

- ◆ Show relationship between the secondary voltage and the secondary current for an electrical section
- ◆ Should be taken when a precipitator is new and clean
- ◆ Should be taken during normal gas load operation
- ◆ Should be compared before and after outages to determine if shifts have occurred
- ◆ Verifies the presence of back corona

Voltage vs. Current (VI) Curves

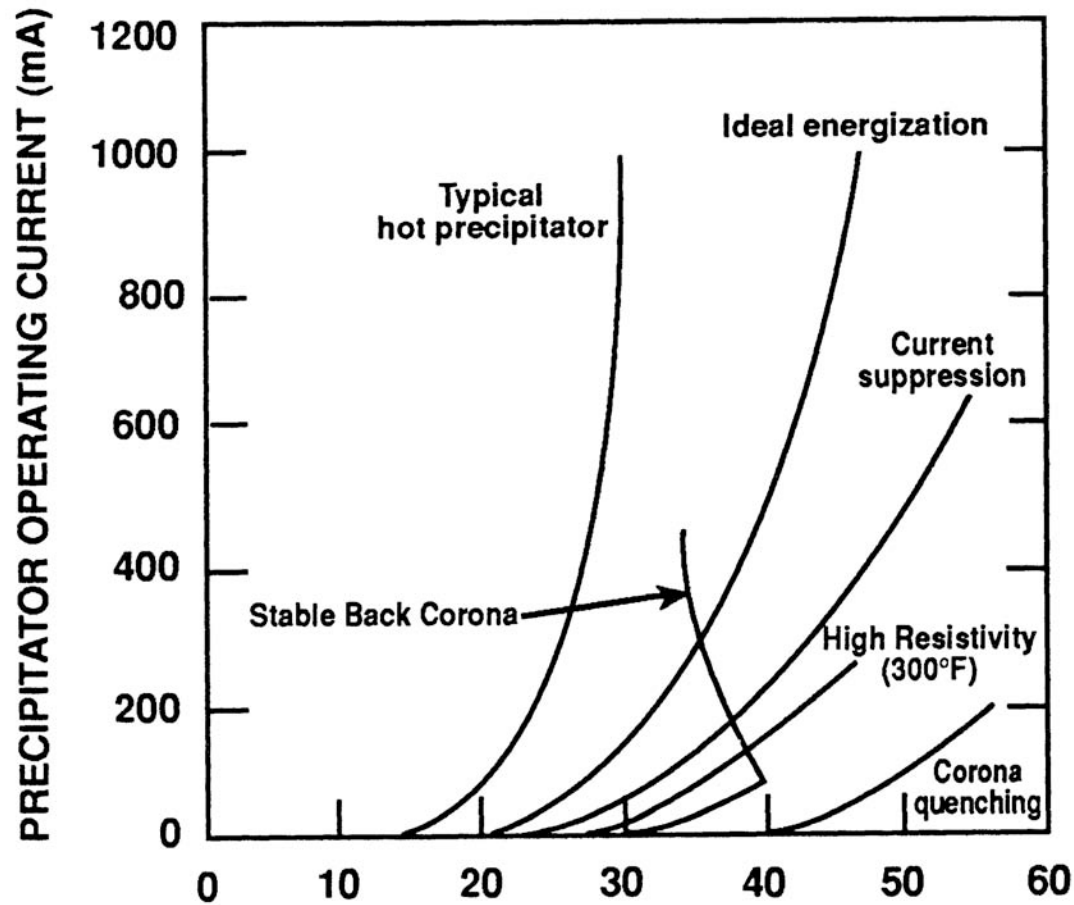

Voltage vs. Current (VI) Curves

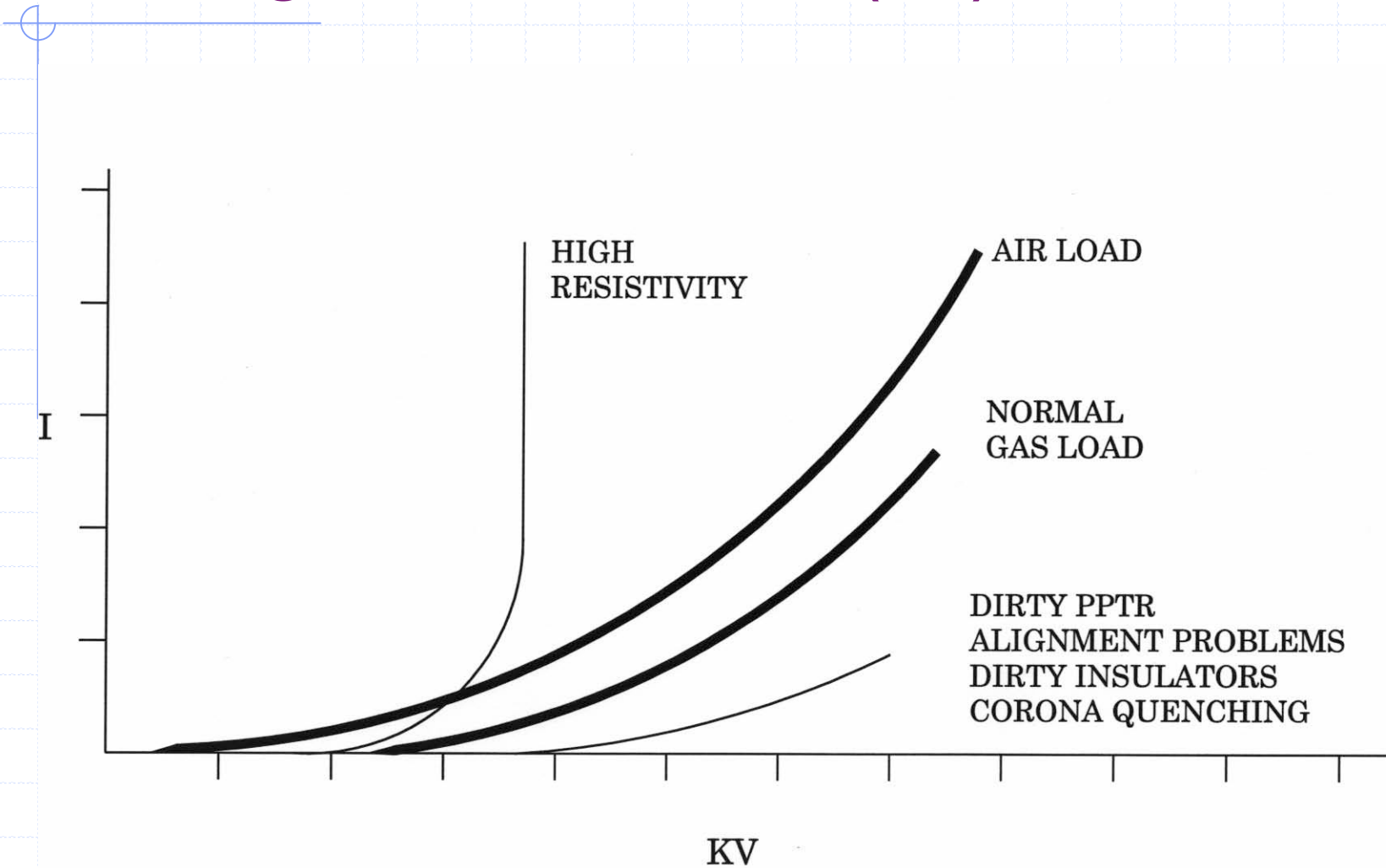



Electrode Management

Electrode Management

◆ The Voltage vs. Current (VI) Relationship Can be Adjusted by Changing:

- DE Corona Generator Spacing
- Length of DE Corona Generators
- Corona Generator Alignment
- Number of Discharge Electrodes

Electrode Management

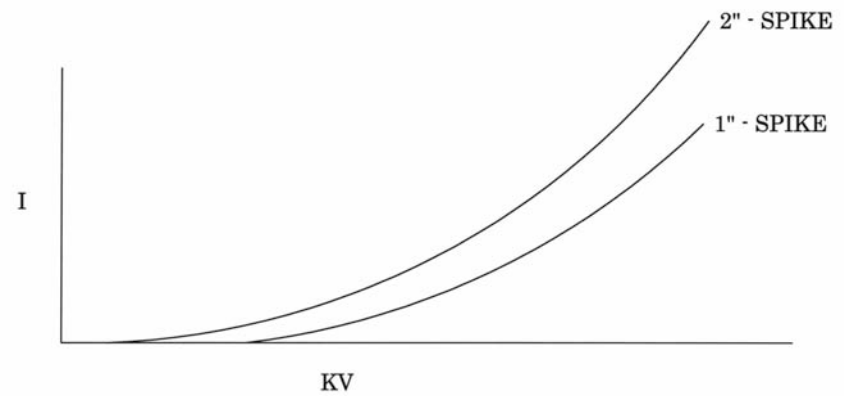
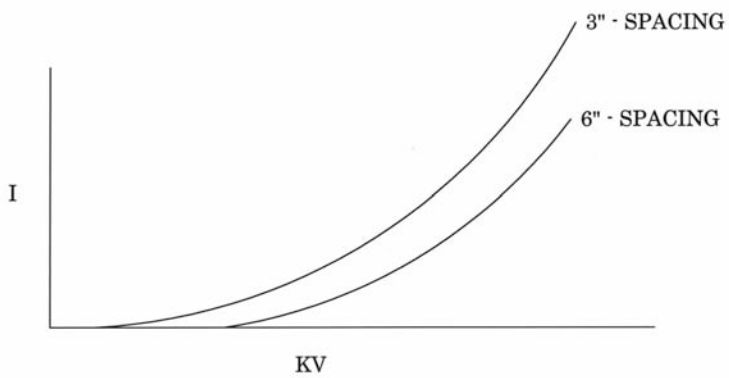
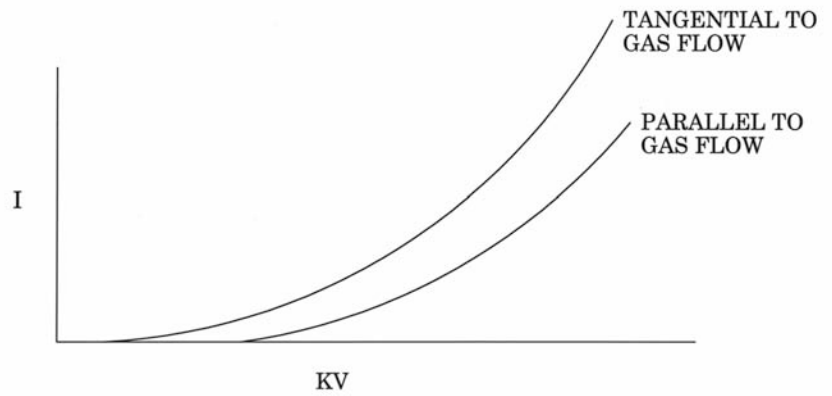
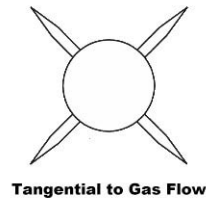
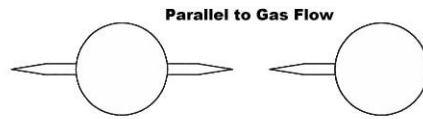
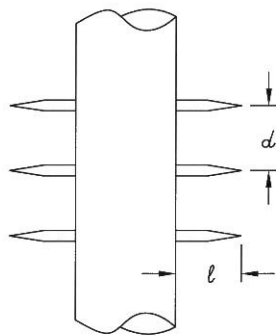

Electrode Management

◆ Why Change the VI Relationship

- High inlet particulate loading
 - ◆ Overcome corona suppression
 - ◆ Reduce low level sparking
- High Resistivity
 - ◆ Overcome the resistance to accept charge
 - ◆ Manage back corona (back ionization)
- Low Resistivity
 - ◆ Minimize power requirements

Wire Breakage

Wire Breakage

- ◆ Sharp needle point types of wire breakage are indicative of close clearance or buildup
- ◆ Blunt breaks at other than the ends of the wires indicate chemical corrosion or a brittleness in the wire
- ◆ Blunt breaks at the ends of the wires indicate work hardening of the wire

Wire Breakage

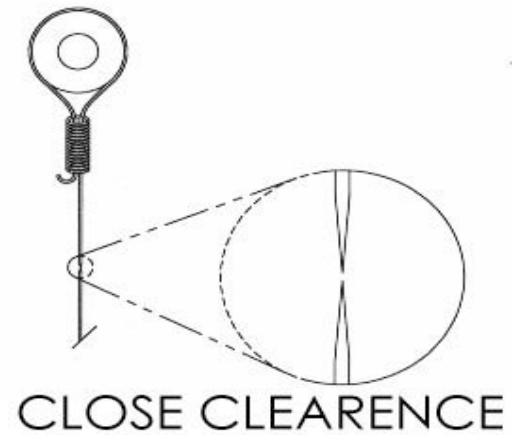
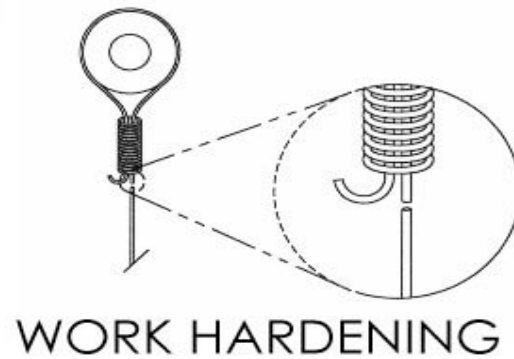
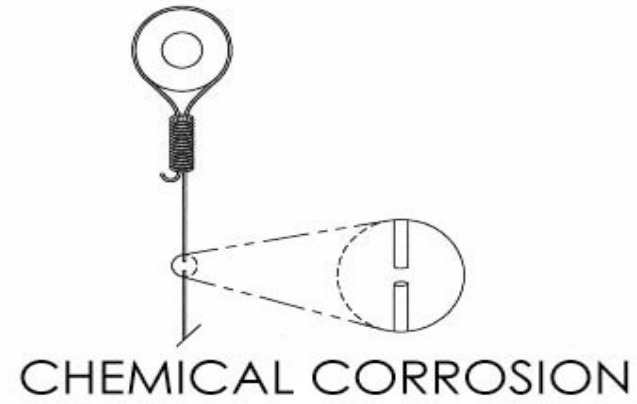
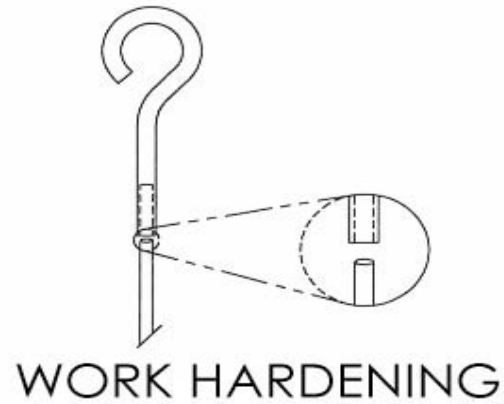



Electrical Control Systems

Electrical Control Systems

- ◆ Stand Alone Microprocessor Based TR Controls
- ◆ Stand Alone Microprocessor Based Rapper Controls
- ◆ Direct Data & Control To & From Plant DCS or PLC
- ◆ Individual Central Control Systems

Electrical Control Systems

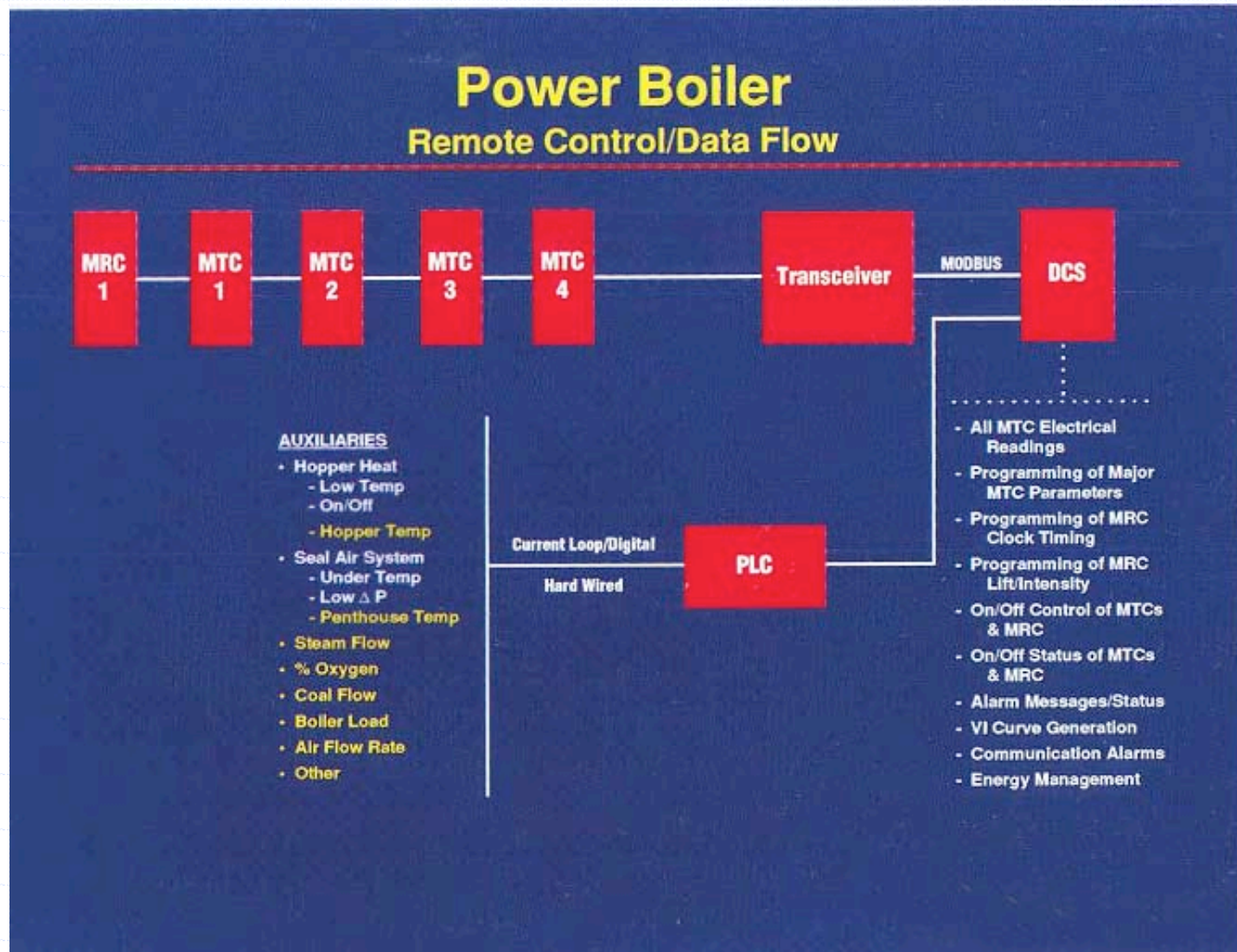

Electrical Control Systems

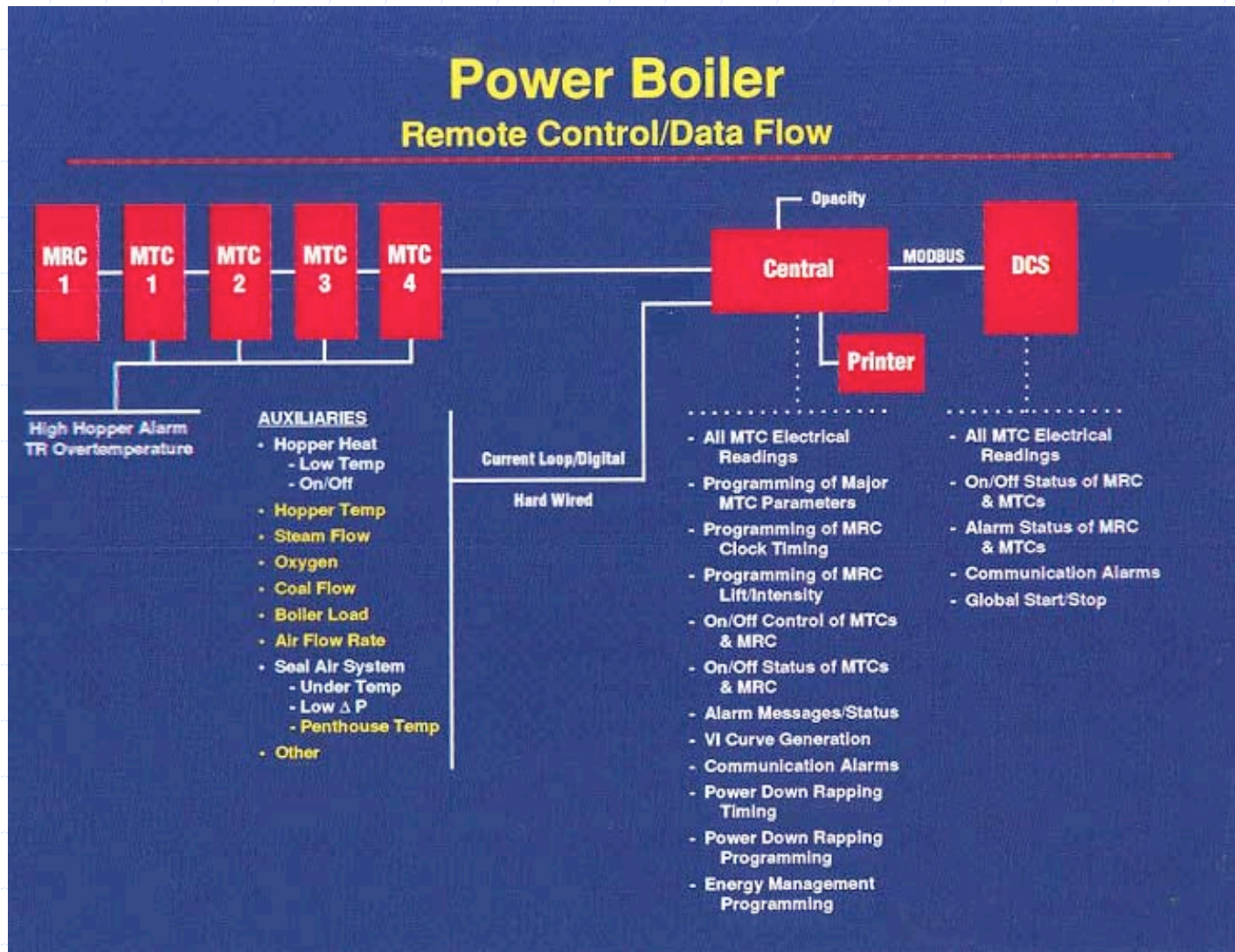

What Electrical Readings Can Tell Us

What Electrical Readings Can Tell Us

- ◆ When Discharge Electrodes are Built-up
 - Secondary current will be suppressed while secondary voltage is relatively normal
- ◆ When Plates are Built-up
 - Secondary voltage and current will be suppressed on a cyclic basis
- ◆ When ESP is overloaded with Particulate
 - Both voltage and current are low, usually due to sparking at lower than normal KV levels
- ◆ When a TR is Grounded
 - Primary voltage will be very low while secondary and primary currents are at or near maximum



Hopper Problems

Hopper Problems

◆ Rat Holing

- Particulate sticks to hopper skin usually due to cold temperature or ambient in-leakage – empties center only

◆ Bridging

- Particulate collects moisture as it cools and tends to become cemented together – empties only below bridge

◆ Clinker Clog

- Arcing/sparking through the particulate to ground and fusing the ash into large solid shapes that get stuck in the hopper outlet

◆ Plugged

- Particulate has cooled, picked up moisture, and become sticky and refuses to flow

Hopper Problems

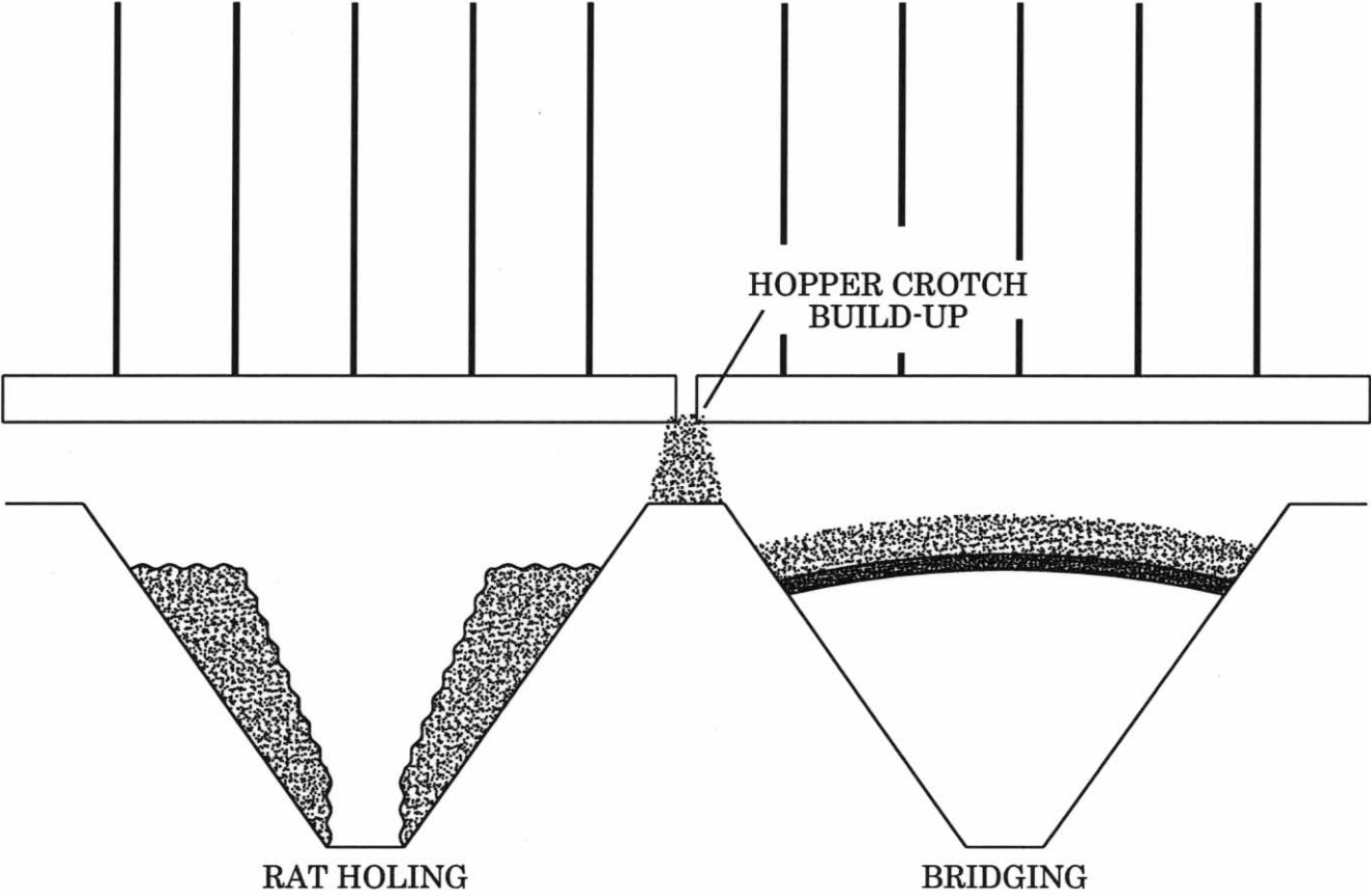

Record Keeping

Record Keeping

- ◆ For Internal Inspections Draw a Road Map
 - Show and number ducts
 - Show and number collecting plates
 - Show and number discharge electrodes
 - Show legend of problems and section location

Record Keeping

Inspected By: _____ Date: _____

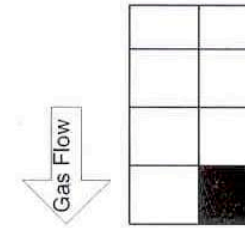
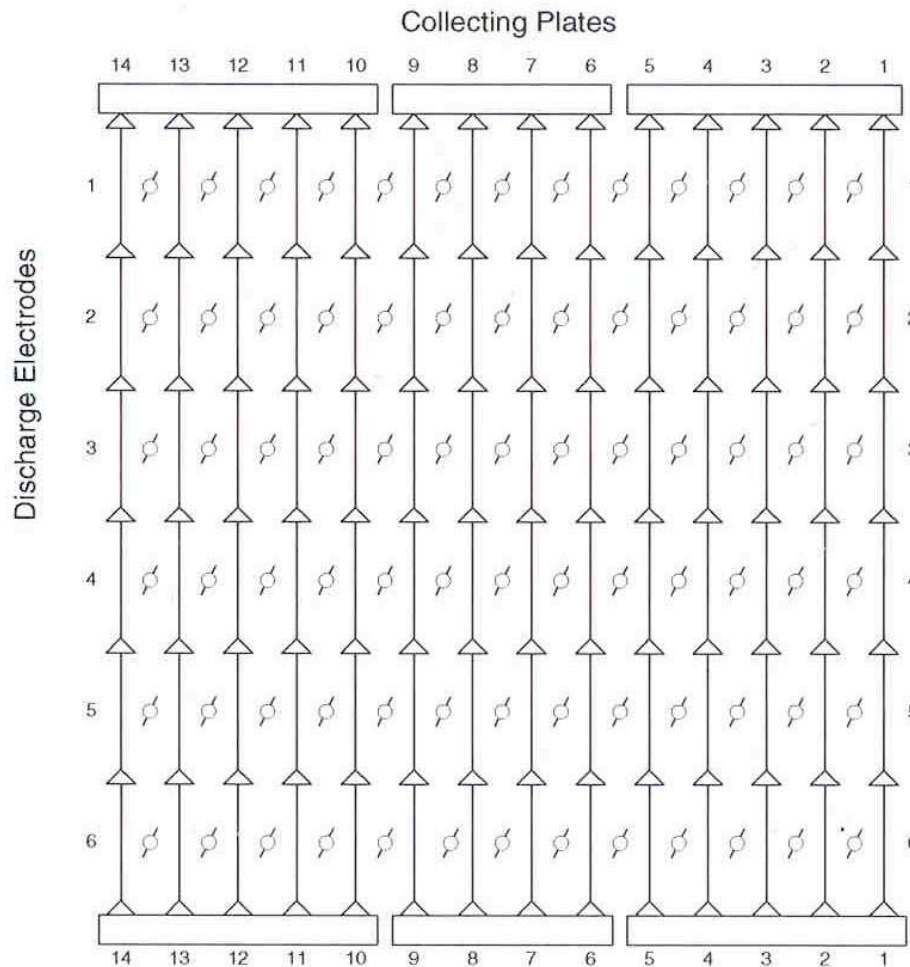

Legend

1	Kinked Discharge Electrode
2	Warped Discharge Electrode Frame
3	Broken Discharge Electrode Frame
4	Broken Discharge Electrode
5	Bowed Collecting Electrode
6	Heavy dust Build-Up
7	Heavy Corrosion
8	Rapper Alignment Off-Center
9	Improper Collecting Electrode Spacing
10	Improper Discharge Electrode-To-Collecting Electrode Spacing
11	Other

Record Keeping

Inspected By: _____ Date: _____

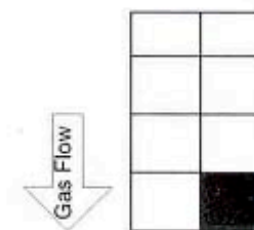
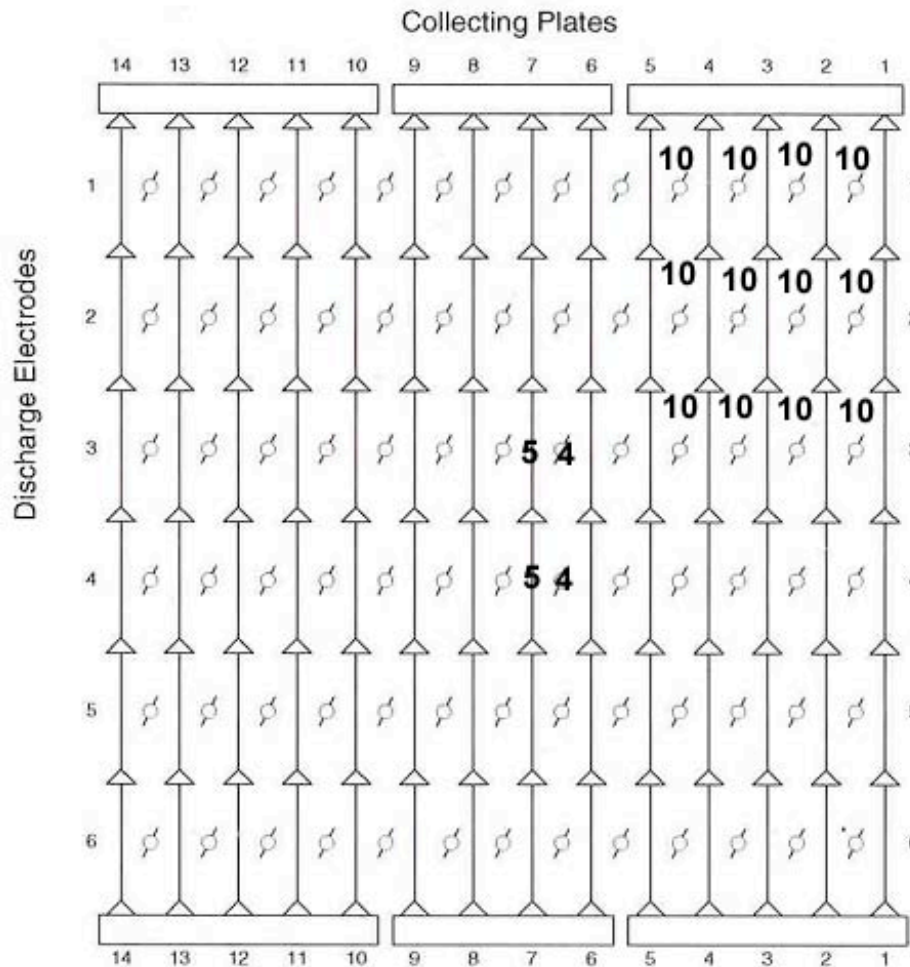

Legend

1	Kinked Discharge Electrode
2	Warped Discharge Electrode Frame
3	Broken Discharge Electrode Frame
4	Broken Discharge Electrode
5	Bowed Collecting Electrode
6	Heavy dust Build-Up
7	Heavy Corrosion
8	Rapper Alignment Off-Center
9	Improper Collecting Electrode Spacing
10	Improper Discharge Electrode-To-Collecting Electrode Spacing
11	Other



Let's Sum it Up

- ◆ Although the precipitator is a rather simple device in terms of the basis of operation, there are numerous factors that can both positively and negatively effect the day to day efficiency.
- ◆ Stay aware of what these factors are, understand their effect, and optimize them for best performance.
- ◆ There are consultants who have spent their lifetime solving precipitator problems. Don't be shy about asking for help. In the long run it will save you time and money.